

JOINT CONFERENCE • OCTOBER 21-24, 2005 • HAMPTON CONVENTION CENTER • HAMPTON, VIRGINIA

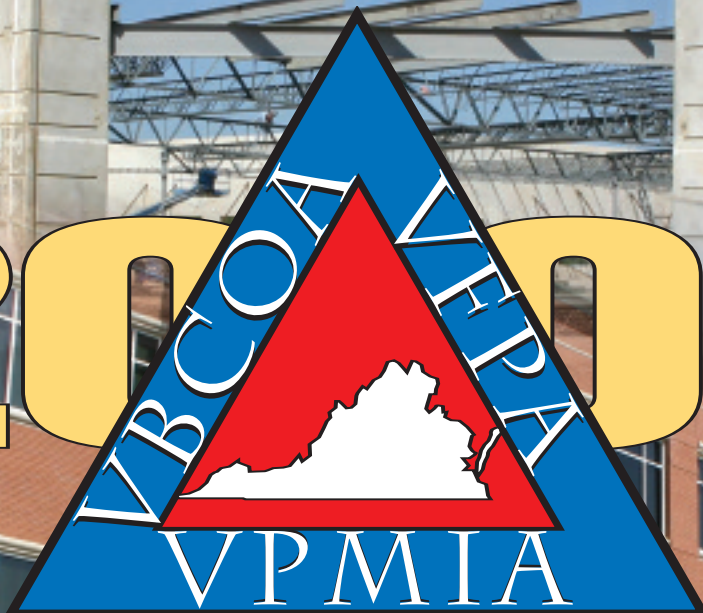

# 2005

The logos for the Virginia Building Code Officials Association (VBCOA) and the Virginia Professional Mechanical Insulators Association (VPMIA) are overlaid on the year "2005". The VBCOA logo is a blue triangle with a white outline, containing a red triangle with a white map of Virginia. The VPMIA logo is a blue triangle with a white outline, containing the letters "VPMIA" in white.

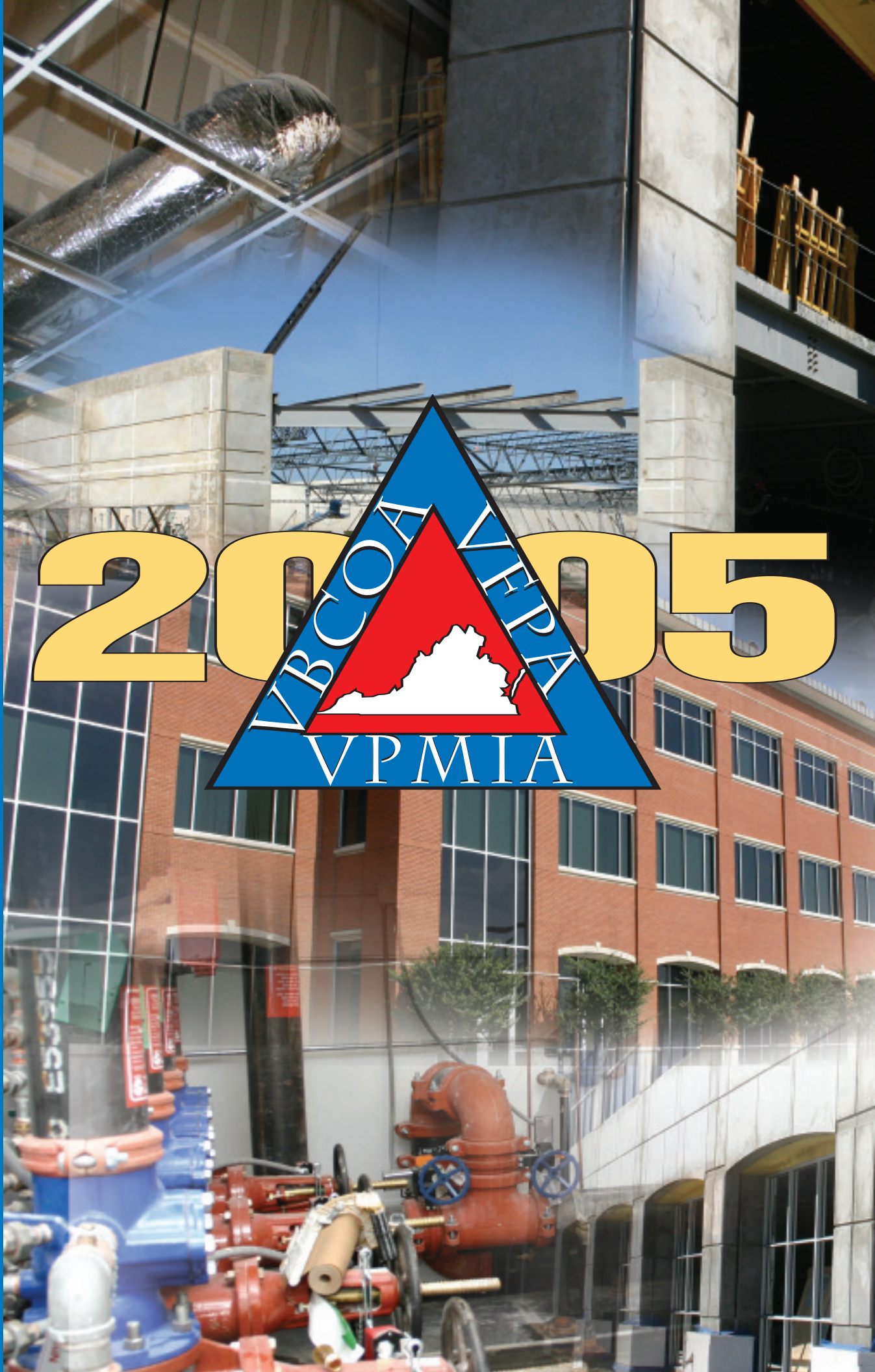

# ICC is Proud to Serve Virginia

Thank you for your commitment to the public safety of Virginia's citizens. Together, we can protect the health, safety and welfare of communities for years to come by creating better buildings.

ICC's mission is to provide the highest quality codes, standards, products and services for all concerned with the safety and performance of the built environment. It is our pleasure to offer Virginia's professionals in building design, construction and inspection:

## QUALITY PRODUCTS

- The latest technical requirements
- Handbooks, commentaries and study tools
- Easy-to-use field references

## EXPERT TECHNICAL ADVICE

- Plan Review Service
- Code Opinions
- Online Bulletin Boards

## PROFESSIONAL DEVELOPMENT OPPORTUNITIES

- Training and Education
- Certification
- Contractor Licensing

## MEMBERSHIP BENEFITS

- Special discounts
- Networking
- Code news and industry updates

## EVALUATION SERVICE

- Reports covering code-compliant building systems components

## ACCREDITATION SERVICE

- Reports covering the acceptability of third-party testing and certification agencies

[www.iccsafe.org](http://www.iccsafe.org) • 1-888-ICC-SAFE  
(422-7233)



People Helping People  
Build a Safer World™





## Dear Joint Conference Participant,

Welcome to the first joint meeting of the Virginia Building and Code Officials Association, Virginia Fire Prevention Association, and the Virginian Plumbing and Mechanical Inspectors Association – An educational and networking conference in Hampton, Virginia. This historic event brings together several of the key organizations dedicated to the safety of all whom live, work, and visit Virginia.

The conference will give each of you a chance to develop your code knowledge and earn valued continuing education towards certification maintenance. But more importantly, you will have the opportunity to network with your peers whom have a wide variety of backgrounds and experiences from around the state. The opportunities will be endless as you will not only be in classroom settings with some of the top educators in the country, but will enjoy round table discussions, joint training programs, access to product vendors, and a wide variety of social and entertainment venues.

We also hope that you enjoy the brand new Hampton Convention Center and the nearby shopping and entertainment opportunities. The Convention Center is within walking distance of the Coliseum Mall district to the west and the newly opened Power Plant food and entertainment district to the south. And don't forget the "Outdoorsman's Mecca" Bass Pro Shop and Outdoor World within eyesight of the conference!

Hampton is home to many military facilities that include the Langley Air Force Master Jet Base and historic Fort Monroe. Hampton also offers a beautiful downtown waterfront district with fishing and sightseeing boats, marinas, the Air and Space Museum, wonderful dining and shopping, and a view of the beautiful Hampton University Campus. Just to the north are the Chesapeake Bay and Buckroe Beach Park where you can stroll and watch Navy, commercial, and cruise ships come in and out of the Hampton Roads harbor. You are less than 25 minutes from Historic Colonial Williamsburg, Jamestown and Yorktown to the west. To the east you will find the Virginia Beach waterfront and the vibrant shopping, museum, and entertainment areas of downtown Norfolk.

The officers and board members of the hosting organizations want to thank you for being a part of this event - one of the largest gatherings of building and fire safety professionals in Virginia. Your role in keeping your communities safe is an important one, and we are honored to welcome you to the 2005 Joint Conference. Thank you for being a part of history!

**John Catlett**  
*VBCOA President*

**M.J. "Flo" Fournoy**  
*VFPA President*

**Mike Thuot**  
*VPMIA President*

# Welcome to the Hampton Roads Convention Center

Agenda for Friday	5
...Saturday	9
...Cracker Barrel	10
...Sunday	15
...Monday	16
Spouse Program	19
Special thanks	20



COVER PHOTO CREDIT:  
The six photos comprising the cover montage are courtesy of constructionphotographs.com

## FIRST FLOOR

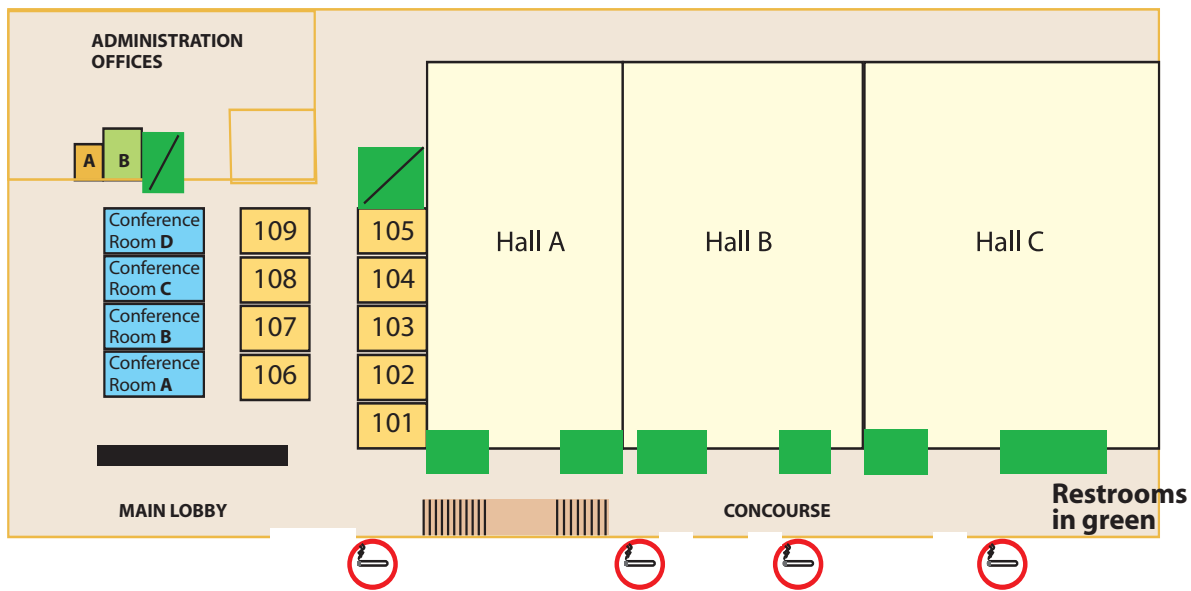

## SECOND FLOOR

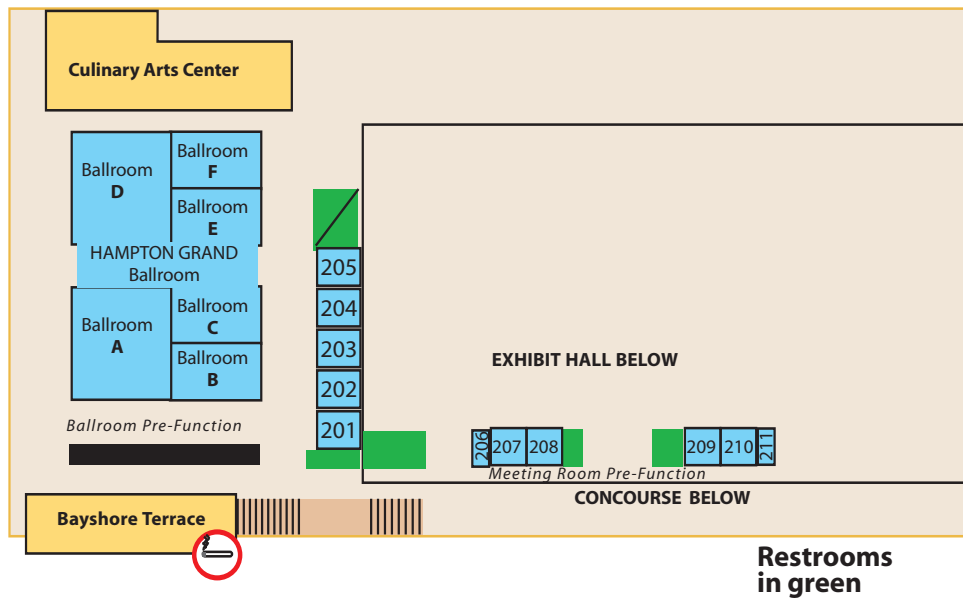

# Conference Agenda



**JOINT CONFERENCE • HAMPTON, VIRGINIA**

OCTOBER 21- 24, 2005

**Hampton Roads Convention Center**

## Friday October 21

**9:00— 5:00**

**REGISTRATION**

**MAIN LOBBY**

*Please take time to visit the exhibitor's area in Conference rooms A and B*

**General Motors expects to roll out a hydrogen-powered vehicle by 2010 but** between

10:30 and 12:30 today, GM has graciously provided us one for "rides and drives." Get more particulars at our Registration Desk.



**10:00—12:00**

**Classes begin**

### Track I

**Rooms 102/103**

**Overview of the 2003 International Fire Code**

ICC instructor Kevin Scott, Deputy Chief  
Kern County Fire Department Bakersfield, CA

### Track II

**Rooms 104/105**

**Property Maintenance – Diversity – Mediation/  
Conflict Resolution**

Director at the Community Mediation Center  
and General District Court Case Manager, Andrea Palmisano

**12:00— 1:00**

**Lunch provided in Conference Rooms C and D**

*Please take time to visit the exhibitor's area in Conference rooms A and B*

**1:00—2:30**

**Classes continue**

### Track I

**Rooms 102/103**

**Overview of the 2003 International Fire Code, continued**

ICC instructor Kevin Scott

### Track II

**Rooms 104/105**

**Property Maintenance – Wood Deterioration Process**

President of McPherson Boyles & Associates, P.C. Structural Engineers  
Roland E. McPherson

*(Agenda continues on next page)*

**Friday October 21, continued**

**2:30—3:00**

**BREAK**

*Please take time to visit the exhibitor's area in Conference rooms A and B*

**3:00—5:00**

**Classes continue**

### **Track I**

**2003 International Fire Code Hazardous Materials**

ICC instructor Kevin Scott

**Rooms 102/103**

### **Track II**

**Property Maintenance – Exterior Siding  
Application/ Maintenance**

District Manager with Norandex/Reynolds, John R. Hurd

**Rooms 104/105**

**5:00—7:00**

**Dinner on your own –**

*Visit one of the many fine restaurants Hampton has to offer*

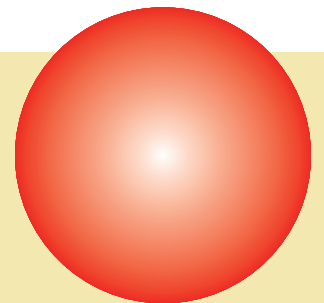
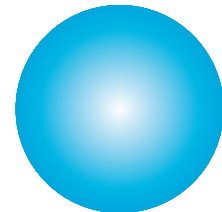
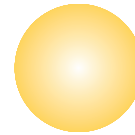

**7:00—10:00**

## ***Presidents/Exhibitors Reception***

*Located in the conference rooms Convention Center  
in Conference Rooms A-B-C-D.*

**Don't miss this opportunity** to network with all the attendees and exhibitors while visiting product display areas in a casual atmosphere. Light food will be provided, along with live entertainment, *VBCOA member Donald Goodwin's band.*

*(Agenda continues on page 9)*

# Gas pipe? Think fast.



## It's easy to spot a faster way: Viega ProPressG™ with Smart Connect.™

- Proven reliability
- Faster installation
- Added peace of mind

Are you still wasting time by cutting threads and screwing connections onto black iron pipe? Now you can install copper pipe for LP gas, fuel oil, or natural gas in record time,

but only if you use the Viega ProPressG system.

ProPressG fittings are available in sizes from 1/2" to 2". A yellow HNBR sealing element is designed to last the life of types K and L copper tubing.



Viega fittings + RIDGID tools make it a ProPress System



"ProPressG has kept us professionally ahead of schedule on these 83 units using 25,000 feet of gas lines. It is a great extension of the ProPress System that we have been using successfully for years."

*Terry Ross, RAAB Mechanical*

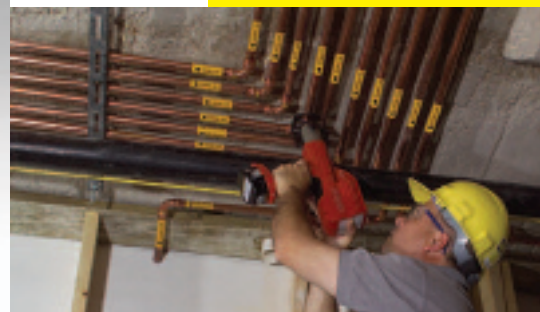

Only CSA approved ProPressG gas fittings, with yellow spots, offer the patented Smart Connect Feature, a quick and easy way for installers to identify unpressed connections.



For more information about Viega fittings and the Viega ProPressG system, call toll free 1-877-VIEGA-NA or visit [viega.com](http://viega.com).

Viega... first to bring copper press technology to gas pipe installation.



ProPress and ProPressG are registered trademarks of Viega.

AD-PPG-02

## JAMES LEE WITT



James Lee Witt is currently Chairman and Chief Executive Officer of James Lee Witt Associates, LLC providing disaster recovery and mitigation management services to state and local governments, educational institutions, the international community and corporations.

In 2003, Mr. Witt became the Chief Executive Officer of the International Code Council (ICC), a 50,000-member association dedicated to building safety, develops the codes used to construct residential and commercial buildings, including homes and schools. Through its founders, the ICC has more than 190 years of collective experience developing building safety codes that save lives. The majority of U.S. cities, counties and states that adopt codes choose building and fire safety codes developed by the ICC.

James Lee Witt has over 25 years of disaster management experience, culminating in his appointment as the Director of the Federal Emergency Management Agency, where he served from 1993-2001. In this capacity, he is credited with turning FEMA from an unsuccessful bureaucratic agency to an internationally lauded all-hazards disaster management agency. His leadership abilities have been praised by nationally recognized organizations, including the Council for Excellence in Government, Harvard University's Kennedy School of Government, and the National Association of Broadcasters.

Mr. Witt was appointed by President Clinton and confirmed by the U.S. Senate as Director of the Federal Emergency Management Agency in April 1993. In February 1996, President Clinton elevated Mr. Witt to cabinet status - a first for a FEMA Director. As FEMA Director, Mr. Witt coordinated federal disaster relief on behalf of President Clinton, including the response and recovery activities of 28 federal agencies and departments, the American Red Cross and other voluntary agencies. He also oversaw the National Flood Insurance Program, the U.S. Fire Administration and other pro-active mitigation activities that reduce loss of life

and property from all types of hazards. Mr. Witt directed 2,500 employees located in Washington, DC and 10 regional offices. From 1993 to 2000, Mr. Witt oversaw more than 350 disasters. More importantly, he was responsible for response and recovery operations for six of the ten most devastating disasters of all time, including the most costly flood disaster in the nation's history, the most costly earthquake, and a dozen damaging hurricanes.

As Director of FEMA, Mr. Witt was the visionary and architect of national government programs related to emergency preparedness and mitigation, response, recovery. In addition to his experience in emergency management on the State and local level, Mr. Witt has expertise integrating community-based disaster management with national emergency management strategy. He initiated Project Impact, the first federally funded program dealing with emergency preparedness and mitigation at the local level.

Mr. Witt integrated flood mitigation, control and protection into FEMA's policy. After the devastating Midwest floods of 1993, Mr. Witt pursued an aggressive flood prone property acquisition and relocation program. By purchasing properties that were repeatedly flooded, he saved taxpayers millions of dollars when floods again ravaged the same Midwest area again in 1995.

Mr. Witt's professional career includes the formation of Witt Construction, a commercial and residential construction company. After 12 years as a successful businessman and community leader, he was elected County Judge for Yell County, serving as the chief elected official for the county, with judicial responsibilities for county and juvenile court. At age 34, he was the youngest elected official in Arkansas, and was later honored for his accomplishments by the National Association of Counties. After being re-elected six times to the position, Mr. Witt was tapped by then-Governor Bill Clinton to assume leadership of the Arkansas Office of Emergency Services (OES). He served as the Director of the Arkansas OES for four years.



**Saturday      October 22**

<b>8:30—12:00</b>	<b>REGISTRATION</b> <i>Please take time to visit the exhibitor's area in Conference rooms A and B</i>	<b>MAIN LOBBY</b>
<b>9:00—9:45</b>	<b>Welcome and Opening Session</b> —All to attend Invited Guest Speakers: Mayor Ross A. Kearney II, City of Hampton, and The Honorable Alan Diamonstein Former Delegate in the General Assembly and Chairman of Housing Study Commission	<b>Rooms 106/107</b>
<b>10:00—12:00</b>	<b>Class: Fire Protection—Safety and Evacuation Planning</b> Training and Consulting, Dave Diamantes	<b>Rooms 104/105</b>
<b>10:00—11:00</b>	<b>VBCOA General Membership Meeting</b>	<b>Rooms 106/107</b>
<b>11:00—12:00</b>	<b>VPMIA General Membership/BOD Meeting</b>	<b>Rooms 102/103</b>
<b>12:00—1:30</b>	<b>Luncheon all to attend Upstairs</b> Guest Speaker: ICC James Lee Witt, former Director of FEMA  VBCOA awards presentation	<b>Ballroom A</b>

***Hurricane Katrina Relief—A United Response***



***Add your donation to the Relief Fund Box located at the Registration table; our three organizations will submit a combined contribution from Virginia to the ICCF's Hurricane Katrina Relief Fund.***

***(See page 13 for more details)***

# Participate in our

## TABLE # 1

Benefits of the Charlotte piping products in today's code.

Bill Morris

Charlotte Pipe and Foundry

## TABLE # 2

"Connect" with the code applications associated USP's products.

USP-United Steel Products Company

Structural Connectors

## TABLE # 3

Benefits and advantages of ICC services

Dave Conover

International Code Council (ICC)

## TABLE # 7

See the benefits of the many products Sioux Chief offers

Rex Baer

Sioux Chief Manufacturing Company Inc.

## TABLE #8

Building Ventilation Openings

Steve Ardito

SMART VENT

9.Planning, zoning, code enforce-

## TABLE #9

Planning, zoning, code enforcement, building inspection software.

Dan Kenney

BUILDERadius Inc.

## TABLE #13

Bill Hartz

Thomson Prometric.

## TABLE #14

John Geniesse

The Door and Hardware Institute.

## TABLE #15

Common applications of wet venting plumbing systems.

Ed Roston

City of Manassas.

## TABLE #19

Mobile inspections and inspection software

Jean Vallee

Windoware

## TABLE #20

Document Imaging/ Electronic Records/Agenda Management.

Dave Gephart

MCCI

## TABLE #21

Advantages of copper piping installations

Dave Powell

Copper Development Association

# **Cracker Barrel!**

**TABLE # 4**

**Government software**

**Manuel McMin  
CSDC Systems Inc.**

**TABLE # 5**

**Steve Bartlett with Mobilehwy**

**TABLE # 6**

**Fire retardants and mold inhibitors  
for wood framed structures  
Jeffrey Copeland  
No-Burn of Northern Virginia**

**TABLE #10**

**Envirosafe Plus DOT Borate Pressure  
Treatment Chemical For Exterior  
Applications  
Derreck Manteau  
Wood Treatment Products Inc.**

**TABLE #11**

**CRACK THE CODE-Focus on fire  
retardants, Revealing applications,  
Tantalizing case studies, Wild land  
initiatives  
Joe Holland**

**TABLE #12**

**Mike Bratcher with ISO.**

**Hoover Wood Treated Products**

**TABLE #16**

**Hazard Mitigation Program  
Deborah Mills  
Department of Emergency  
Management.**

**TABLE #17**

**Benefits and services UL has to  
offer.  
John Wiggins and Al Ramirez  
Underwriters Laboratory**

**TABLE #18**

**Issues associated with gas appliance  
installations  
Hearth Education Foundation**

**TABLE #16**

**Firestop products, systems,  
applications and solutions  
Mike Dragen  
Hilti**

**TABLE #23**

**Training and Consulting  
Dave Diamantes  
Safety and Evacuation Planning**

**TABLE #24**

**Everything You Always Wanted To  
Know About the Pre-Renovation  
Education Rule  
Kris Beethoven Meek  
Lead-Safe Virginia Program, Virginia**

**Department of Health**

**Saturday October 22, continued**

**1:00—2:00**

**REGISTRATION**

**MAIN LOBBY**

**2:00—5:00**

## **Cracker Barrel**

**Conference Rms A-B-C-D**

Participating exhibitors and presenters from various industry professions provide “round” table training and discussion in small group settings. These presentations run for approximately 20 minutes each then a quick break and on to the next table! Participate in this great learning opportunity! Take advantage of this exposure to new and improved industry technologies. You will have the ability to gain information on several different topics while enjoying the casual atmosphere.

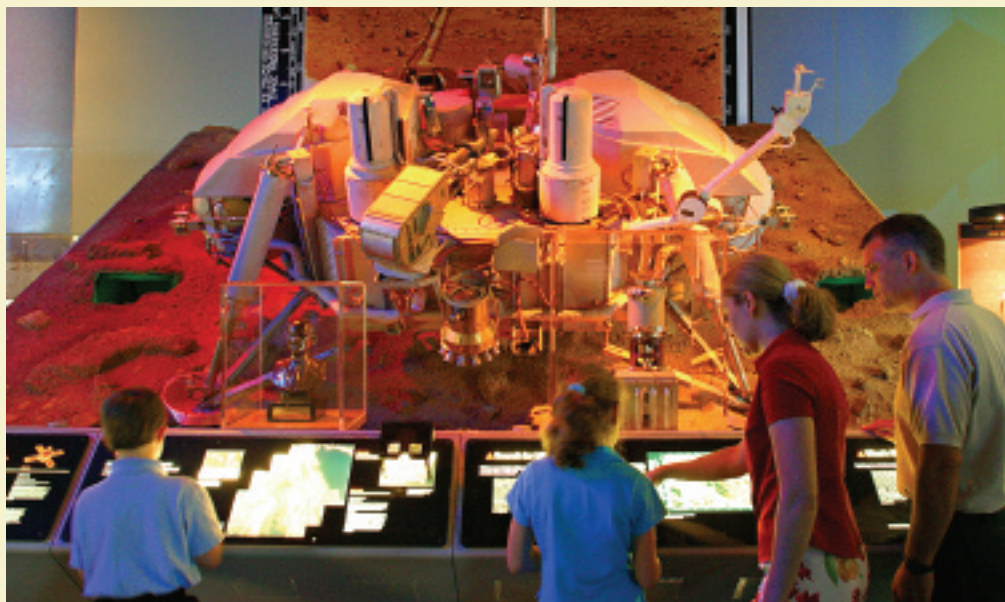

**6:00—10:00**

## **Off-Site Dinner Event**

**Air and Space Center**

Dinner will be provided at the **Air and Space Center**. Interact with all the attendees while enjoying the aeronautical displays provided in the Hampton Air and Space Center. Come enjoy a full night of fun and “casino” excitement. Try your luck at Texas Hold’em, blackjack, or maybe roulette, as a portion of the Air and Space Center will be set up in a Las Vegas style atmosphere. Relax, have fun and enjoy the evening with live entertainment provided by VBCOA member Richard Ritter and his band.

**Transportation is provided to and from the event site.**

Transportation is provided from the Embassy Suites to the Hampton Air and Space Center continuous from **5:45pm until 10:15pm**

*(Agenda continues on page 15)*

# VBCOA Region V is a proud supporter of the

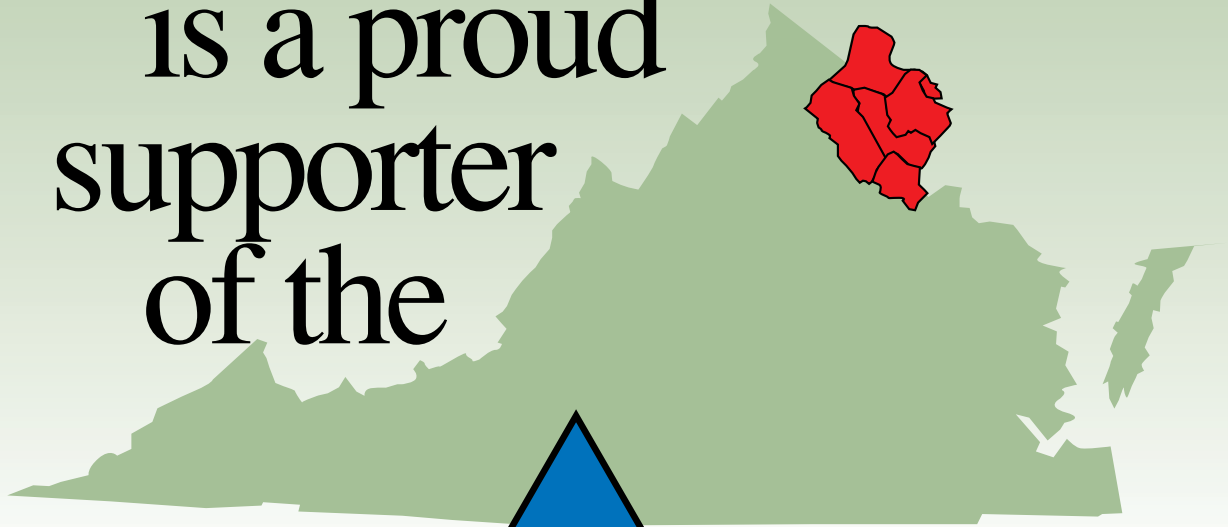

**JOINT CONFERENCE • HAMPTON, VIRGINIA**

OCTOBER 21- 24, 2005

---

## Hurricane Katrina Disaster Relief

---

In the wake of the devastation left behind by Hurricane Katrina, the International Code Council Foundation (ICCF) has established a relief fund that will go towards the rebuilding efforts for victims of this disaster.

To make a tax deductible donation to the ICCF Hurricane Katrina Relief Fund, you can mail donations to: ICCF, Attention: Accounts Receivable, 4051 W. Flossmoor Road, Country Club Hills, IL 60478-5795.  
**Checks should show a notation for the "ICCF Katrina Relief Fund"**

---

# THERMOPAN<sup>®</sup>

PATENTED USA AND CANADA

THE RESIDENTIAL PANNING STANDARD FOR NORTH AMERICA!

**THERMO-PAN™** is a high-quality sheet metal alternative for constructing return air ducts.

- No duct noise • Satisfied homeowners
- Excellent for open web trusses
- Lightweight • Easy to install
- Four (4) precision pre-cut header sizes available
- Will not sustain combustion



ICC LEGACY  
REPORT 95-41.01

ICC LEGACY  
REPORT 5398

PRODUCT	ORDER #	SIZE	PC/BOX
THERMO-PAN	16048	16" X 47.5"	25
THERMO-PAN	19048	19.5" X 47.5"	25
THERMO-PAN	22048	22" X 47.5"	25
THERMO-PAN	24048	24" X 47.5"	25
THERMO-PAN	32036	32" X 35.5"	25

PRODUCT	ORDER #	SIZE	PC/BOX
STANDARD HEADER	16012	16" X 12"	250
STANDARD HEADER	16016	16" X 16"	250
I-JOIST HEADER	16017	16" X 17"	250
I-JOIST HEADER	16019	19" X 16"	250

25 PC/PKG  
FOR THE  
CONTRACTOR

25 PC/PKG  
FOR THE  
CONTRACTOR



Precision  
Die Cut and Scored  
**THERMO-HEADERS™**  
are ideal for I-JOIST  
CONSTRUCTION.

## FIRE-RESISTANT THERMOPAN<sup>®</sup>

Look for these ETL<sup>®</sup> test values on every piece of Fire-Resistant Thermo-Pan<sup>®</sup>

Flame Spread Index 25  
Smoke Index 5

**CLASS 1 FIRE RATING**

Fire-Resistant Product	ORDER #	SIZE	PC/BOX
THERMO-PAN	16050	16" x 47.5"	25

Excellent for soffits and tub enclosures

Fire-Resistant Product	ORDER #	SIZE	PC/BOX
STANDARD HEADER	16013	16" x 12"	250
STANDARD HEADER	16015	16" x 16"	250
I-JOIST HEADER	16018	16" x 17"	250
I-JOIST HEADER	16020	19" x 16"	250

## THERMOCONNECTORS<sup>™</sup>

Custom Connect Your Thermo-Pan™

- Save time • Add rigidity

ORDER #	SIZE	PC/BOX
16348	16"	500
4 OTHER SIZES AVAILABLE!		

**THERMO MANUFACTURING INC.**

CANTON, OHIO / TOLL FREE PHONE 888-678-3709 / TOLL FREE FAX 888-678-8711

www.THERMOPAN.com

**Sunday Morning  
October 23**

8:00—12:00

**Golfing or fishing trip** (see the advertisements on-line)



or, on your own,  
explore some of the Hampton area's attractions



12:00—1:30

**Lunch** on your own –  
*Visit one of the many fine restaurants Hampton has to offer*

**Sunday October 23**

**Hampton Roads Convention Center**

1:30—2:00

**REGISTRATION**

**MAIN LOBBY**

2:00—5:00

**Legal Aspects of Code Enforcement—  
All to attend**  
ICC instructor Robert Church  
Assistant City, Attorney Orem, Utah

**Rooms 106/107**

6:00—7:00

**Social Hour** - Live entertainment, the Rhythm Project,  
local high school students perform "Caribbean" theme music.



7:00—10:00

**Banquet**

**Conference Rooms A-B-C-D**

Invited Guest Speaker ICC President Henry Green  
Installation of the 2005/2006 VBCOA Officers

*(Agenda continues on the next page)*

**Monday**      **October 24**

**7:30—12:00**      **REGISTRATION**      **MAIN LOBBY**

**9:00—10:00**      **Classes begin**

**Track I**      **Rooms 104/105**  
**Overview of the 2003 International Building Code**  
ICC staff instructor Mike Pfeiffer, Vice President Codes and Standards

**Track II**      **Rooms 102/103**  
**Commercial Kitchen Hood Systems**  
Doug Horton, Commercial Kitchen/Food Service Specialist/Consultant

**10:00—10:15**      **BREAK**

**10:15—12:00**      **Classes continue**

**Track I**      **Rooms 104/105**  
**2003 International Building Code Overview, *continued***  
ICC staff instructor Mike Pfeiffer

**Track II**      **Rooms 102/103**  
**Commercial Kitchen Hood Systems, *continued***  
Doug Horton, Commercial Kitchen/Food Service Specialist/Consultant

**12:00—1:00**      **Lunch provided in Conference Rooms C and D**  
Guest Speaker  
Bill Shelton, Director, Virginia Department of Housing and  
Community Development

**1:00—4:00**      **Classes continue**

**Track I**      **Rooms 104/105**  
**Overview of the 2003 International Residential Code**  
ICC staff instructor Mike Pfeiffer, Vice President Codes and Standards

**Track II**      **Rooms 102/103**  
**Hydrogen Refueling - The Next Big Step Towards  
A Hydrogen Economy**  
Get the information on Hydrogen refueling station construction  
straight from the professionals who worked on and maintain the  
Shell Hydrogen station in Washington DC.  
Instructors: Brad Smith, Project Manager Shell Hydrogen and  
Tom Joseph, Manager Engineering Air Products

**4:00**      **Adjourn**



# Quality products you can trust...



The Leader in Air Admittance Valve Technology



A worldwide leader in Thermal Management



The Choice of Professionals



Radiant Heating • Hydronic Space Heating • Snow Melting

represented by



**Harry Eklof & Associates, Inc.**

3001 Impala Place • Richmond, VA  
(804) 266-0079 • Fax (804) 266-0280

E-mail: [vainfo@harryeklof.com](mailto:vainfo@harryeklof.com) • [www.harryeklof.com](http://www.harryeklof.com)

## INVISIBLE PROTECTION - VISIBLE QUALITY

INTERIOR

**PYRO-GUARD®**

EXTERIOR

**EXTERIOR FIRE-X®**

**FIRE  
RETARDANT  
LUMBER  
&  
PLYWOOD**

<b>EXTERIOR FIRE-X</b>  HOOVER TREATED WOOD PRODUCTS THOMSON, GA. R-7002  <b>KDAT</b>	UND. LAB. INC.® CLASSIFIED TREATED LUMBER 15 P9 SURFACE BURNING CHARACTERISTICS		
	SPECIE SYP	FLAMESPREAD 5	30 MINUTE TEST
	NO INCREASE IN THE CLASSIFICATION WHEN SUBJECTED TO THE STANDARD RAIN TEST.		



INSIST ON PROPER TESTING,  
THIRD-PARTY CERTIFICATION  
AND STRICT CODE EVALUATION.

[www.frtw.com](http://www.frtw.com)

Sales: 1-800-531-5558 1-800-TEC-WOOD

**Ready for a quality home?**



**New Shelter Construction, Inc.**

**3714 Mountain Road**

**Haymarket, VA 20169**

**703-369-1552**

**Contact Jeff Heflin, Owner**

**Custom Framed Homes • Log Homes • Additions**

**Full line of doors and windows, specializing in Anderson.**

# Spouse Program FOR JOINT CONFERENCE

OCTOBER 21 - 24, 2005

HAMPTON, VA

## Friday, October 21, 2005 LEAVE 1:00 pm and RETURN 4:30 pm

- 1:15 – 2:00 Tour St. John's Church
- 2:00 – 2:45 Tea and scones at the Gray Goose
- 2:45 – 4:15 Shopping Shabby Chic, Blue Skies, Ceramic Lighthouses, Art by Gerome, Something Different, Old Hampton Quilt Shop and The Brass Shop

## Saturday, October 22, 2005 LEAVE 1:45 pm and RETURN 5:00 pm

- 2:00 – 5:00 Riding Norfolk City Tour—visit downtown Norfolk. View homes along the Hague, old St Paul's Church, the MacArthur Memorial, the historic Freemason District, Nauticus, the Battleship Wisconsin, Town Point Park, the Armed Forces Memorial and the restored waterfront. See lovely historic churches located in downtown Norfolk and Ghent built in the 1800's or early 1900's.

Tour the Moses Myers House—built in 1792, this house is an example of Georgian architecture with Federal interior detailing.

Visit Rowena's—one of the country's leading mail-order companies for fresh baked pound cakes and jams and jellies. Rowena's has been featured in Bon Appetit, Gourmet, Ladies Home Journal, Taste of Home, Redbook and Southern Living. Shop and sample!

## Sunday, October 23, 2005 LEAVE 2:00 pm and RETURN 4:30 pm

- 2:15 – 4:15 Visit Phoebus noted for its' charming architecture and special shops. This area began as a fishing village named Mill Creek after the body of water next to the little water-front settlement. Today the past and present come together to provide unique shopping. Visit Electric Glass Co, McCraft's Gallery, Phoebus Needlework, Craft & Miniatures, the Brickhouse Pottery, Final Touch, one of the many antique shops, or stop in at Sarah's Irish Pub for a bit of refreshment!

## Monday, October 24, 2005 LEAVE 9:45 am and RETURN 1:30 pm

- 10:30 – 1:00 Miss Hampton II Harbor Cruise – a double decked tour boat that takes you to see Blackbeard's Point, Old Point Comfort, Fort Wool and the Norfolk Naval Base. If weather permits, passengers may embark at Fort Wool for a guided tour of the Island fortress.

**Saturday's transportation will be provided by a tour company. For all other activities, we will need to carpool.**

**To participate in the Spouses Program, we do ask that you sign-up to help with the main conference registration table.**





**Mini-Rester™**  
Residential Water Hammer Arrestor

Your permanent, affordable solution to water hammer.



1-800-821-3944 • www.siouxchief.com



List of exhibitors and advertisers

Special thanks

Are you caught in a **paper jam** with plan reviews and inspections?

IBTS is your answer!

**IBTS** Institute  
for Building Technology and Safety

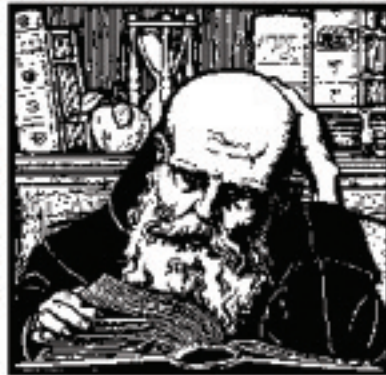
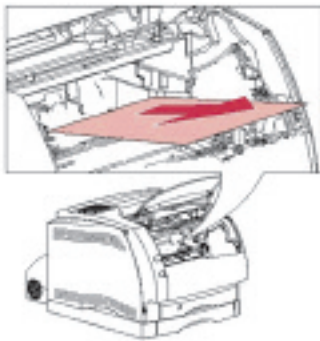

- o ICC and VUSBC plan review and inspection services for jurisdictions in Virginia.
- o Dedicated team to reduce your plan approval and permitting delays.
- o Plan reviewers and inspectors in all disciplines.
- o ICC-certified building officials, plan reviewers, master code professionals and inspectors on staff.
- o Timely, accurate and cost-effective service tailored to your specific needs.

*"The third party reviews conducted by IBTS have been extremely successful in expediting the building permit process. Developers' expenses incurred in this process are minimal compared to the cost of time lost in the county's standard review process."*

- Expedited Review Process for Rehabilitation and New Construction Projects  
Arlington County, Virginia

*"As a result (of IBTS's work)...developers are able to build more quickly, saving thousands of dollars in construction costs..."*

- National Association of Counties Publication, July 2005

Call (703)481-2025 or visit us at:

[www.ibts.org](http://www.ibts.org)

# Leading the way

for Virginia's building,  
maintenance and  
code enforcement  
industry



*The Virginia Building and Code Officials Association is a Statewide organization of construction regulators and representatives dedicated to the protection of the health, safety, and welfare of all persons who live, work, or visit the Commonwealth of Virginia.*

**With the help of the Virginia Building and Code Officials Association, C —**

- Promotes the interests and welfare of the building related code enforcement agencies
- Promotes information sharing within building related code administration and enforcement professions
- Coordinates rules, interpretations, and procedures to promote greater uniformity
- Establishes and maintains clear lines of communication for member participation in the code design process

Visit [www.vbcoa.org](http://www.vbcoa.org) to **keep up** with all the state activity, **check** out the discussion page where you can **track** code issues and **learn** how they are being addressed. Be part of the **Virginia Building Code Officials Association.**



**ICC's 1<sup>st</sup> Chapter of the Year, 2004**

**In the spring of 1968,**

in conjunction with the annual meeting of the Virginia Safety Association, a group of state and local fire marshals/inspectors met to discuss the feasibility of forming an organization of those involved in enforcing and developing fire safety regulations. Those in attendance agreed that such an organization would be beneficial. Several committees were appointed to begin the organizational development needed to get started. A second meeting was held in 1968 at which the constitution and by-laws were adopted.

The Association has been active in promoting State and Local codes and regulations developed to provide safety to life and property from the hazards of fire. Such codes and regulations generally mirror national codes and standards. In 1996 the Virginia Fire Prevention Association felt it would be appropriate to become involved in the development at the National level. To accomplish this we applied to the Building Officials and Code Administrators International, Inc. (BOCA) for affiliation as a chapter. On March 24, 1997 our application was approved by the BOCA Board and we were accepted as Chapter #67. Along with VPMIA and VBCOA, VFPA is now one of the ICC Chapters in Virginia.



# Virginia Fire Prevention Association

See our website [www.vfpa.org](http://www.vfpa.org).

Interested in becoming a member of VFPA?  
Go to [www.vfpa.org/joininfo.html](http://www.vfpa.org/joininfo.html)  
apply on line or print an application. Initial  
membership fee is \$30, annual membership fee  
is \$20. Tell us you saw our ad and get \$10 off your  
initial membership fee.

VFPA  
PO Box 7745  
Woodbridge, VA 22195  
703-257-8455

More than 40 years dedication to the  
code enforcement community.

2005 ICC Merit Award Recipient  
for the Chapter of the Year Contest.

Connect with VPMIA today.



*VPMIA is an association of code professionals dedicated to promotion of uniform enforcement and development of the codes throughout the Commonwealth to assure the health, safety, and welfare of its citizens and any one who may live, work, or visit the state of Virginia.*

*The pursuit of this endeavor is achieved through close, open, and equal working relationships with design professionals, builders, contractors, material manufacturer's and others involved in the construction industry. VPMIA supports the ICC, its goals and mission.*

Virginia Plumbing and Mechanical Inspectors Association  
[www.vpmia.org](http://www.vpmia.org)

