

VIRGINIA PLUMBING & MECHANICAL INSPECTORS ASSOCIATION

VPMIA

Strength Through Leadership, Education and Unity

45th

Annual School of Instruction

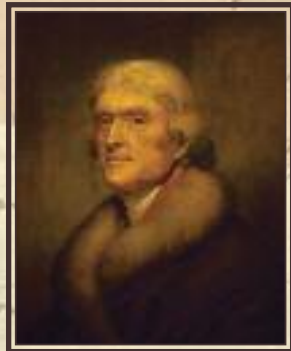

April 9 – 11, 2008

Charlottesville, VA

ICC® Plumbing, Mechanical, Fuel Gas (PMG) Portfolio

Outstanding products designed to fit your needs.



Products—ICC Code books & electronic media, references, training tools and other industry publications provide everything you need to know about Plumbing, Mechanical and Fuel Gas Codes.

Training—ICC offers industry leading customized training programs that can help keep you current on the latest codes and code changes. These programs are offered where and when you need them—on-site, online, or on the phone.

Certification—ICC Certification services are nationally recognized, with easy, web-based registration and results reporting. Keep certifications up-to-date and your career on track with ICC Certifications.

Membership—Join now and save on all ICC products and services, benefits include free code opinions and more discounts.

Find out more about ICC Plumbing, Mechanical, and Fuel Gas (PMG) products and services at the PMG Resource Center.

www.iccsafe.org/PMG
1-888-ICC-SAFE (422-7233), x4PMG
Email: PMGResourcecenter@iccsafe.org



Repairs - Remodeling
Commercial New Construction
Backflow Installations, Repairs & Certification

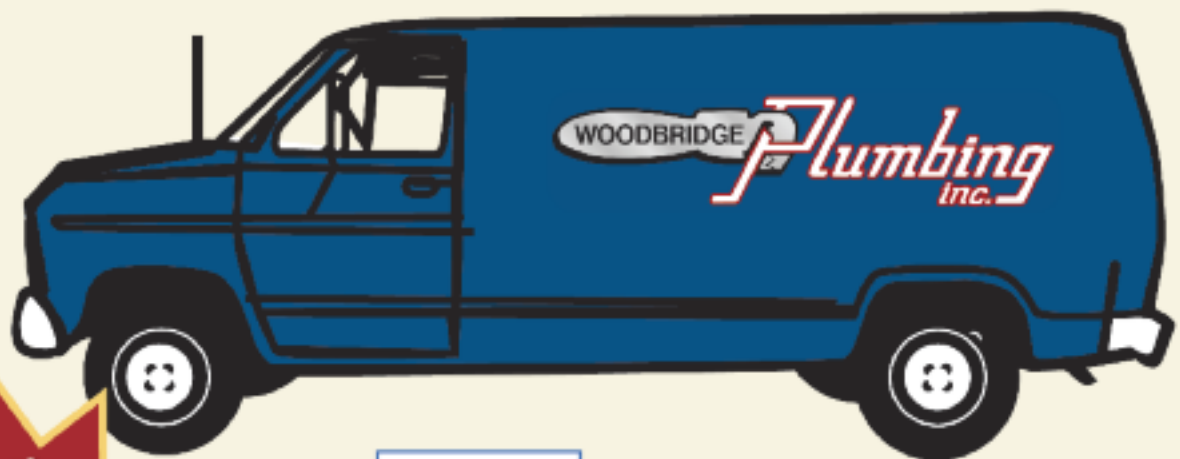

2006
Prince William
Regional Chamber
of Commerce
"Large Business
of the Year"

Local

703-494-9666

Toll-Free

1-800-FIX-MY-LEAK
(1-800-349-6953)

Quality Service Since 1973

Members of BBB, PHCC and PMPV

2705 Code Way • Woodbridge, VA 22192 • www.woodbridgeplumbing.com

Willie Johnson, President • Thomas Wood, CEO



INTERNATIONAL
CODE COUNCIL®

People Helping People Build a Safer World™



“I am the ICC.”



“I am the ICC.”



“I am the ICC.”



“I am the ICC.”

ARE YOU?

Join your peers. Become a member of the International Code Council® now, the organization that can help you build your career and your future.

- Discounts on ICC products and services.
- On-site and on-line training to enhance your knowledge and skills.
- Access to expert code opinions.
- Extensive peer-to-peer collaboration opportunities.

JOIN NOW! www.iccsafe.org/areu
QUESTIONS? 1-888-ICC-SAFE (422-7233), x33804



Welcome to the 45th Annual Virginia Plumbing & Mechanical Inspectors Association School of Instruction in Charlottesville, Virginia.

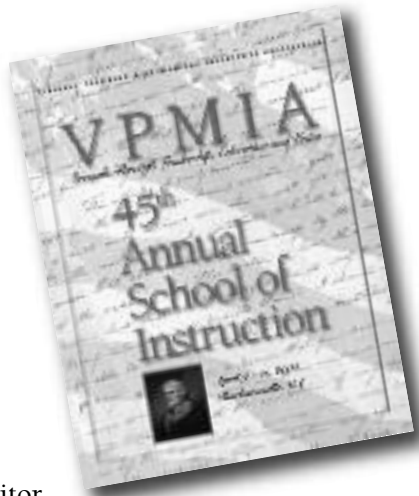

From the Editor

This is your annual resource book for VPMIA. I encourage each and every member, Active and Associate, to take the time and read the entire publication. It is important for all to be aware of VPMIA's History, Constitution, By-Laws, Code of Ethics/Mission, and Strategic Plan. And don't forget about the President's Corner to see what we have accomplished during this past year.

Last, but not least, there is something new in this publication — two cutting-edge, technical articles; the first authored by Lee Clifton of the International Code Council, and the second by Wes Davis of the Air Conditioning Contractors of America. We are grateful for their contributions.

Ron Bladen

CONTENTS

Index to Advertisers	5
President's Corner	6
History	7
Charter Members	9
2008 School of Instruction Program	10
Dedication	11
Resolutions	12
Code of Ethics/Mission	13
Constitution & By-Laws	14
2007-8 Ladies Auxiliary Roster	18
Awards Roster	20
Past Presidents	20
Acknowledgements	22
Strategic Plan	23
Upcoming Events	24
<hr/>	
The International Plumbing Code: Protecting the Environment	27
<i>By Lee Clifton</i>	
Reviewing HVAC Designs	30
<i>By Wes Davis</i>	
<hr/>	
Officers, Directors and Committee Chairmen	35
2007-8 Membership Roster	36
2007-8 Associate Membership Roster	49
New Member Application	51

VPMIA gratefully acknowledges the support of its advertisers, listed below:

International Code Council	IFC	Harry Eklof Associates, Inc.26	Fitzgerald Art & Design47
Woodbridge Plumbing3	New Shelter Construction29	VPMIA AD52
International Code Council4	GSSN32	Ductmate53
L.A. Lacy, Inc.19	L&D Associates, Inc.39	ACME Construction54
Southern Air21	E&E Plumbing and Heating40	PHCCIBC
W.E. Brown, Inc.22	Leonard-Splaine43	ACCABC
The Plumbing Dr.25	Beck Cohen45		

— President's Corner —



It's been my privilege and honor to serve as your President this past year. I want to thank the VPMIA members for giving me the opportunity to lead the organization and keep it moving forward, by standing behind our Code of Ethics and living our Vision, Mission, and Strategic Mission. As we look toward a bigger and better future for our organization, we will keep growing and striving for our Strategic Plan and Mission. Also working with all my fellow board members, district directors and committee chairs has made this another successful year for VPMIA.



This year has been busy again with several members teaching code module classes, and some even traveling around the country teaching. These members need a big pat on the back for doing such a great job and making sacrifices by being away from home and their jobs. We are an organization of committed, dedicated, and very passionate inspectors in making sure the health, safety, and welfare of all Citizens is accomplished. We have several members involved with several other organizations and committees, along with being active in the Region 7 ICC Chapter working with several states to help bring consistency and uniformity of the codes throughout the country. The organizations has been preparing for the upcoming code hearings in California, with many members writing new code changes and having meetings to see as a organization what our positions are on the new changes. Several members will attend the code hearings and will be participants on code committees, such as Plumbing, Fuel Gas, and Mechanical. Remaining active in the organization is why we have been successful in the code development

process and are well respected throughout the state of Virginia and across the country as well. This takes daily and year round involvement to maintain a strong, prosperous, and successful organization. At this time VPMIA is financially strong and scholarship funds are available for members to attend code hearings. This is your opportunity to step up, serve and get involved with what we are all about.

VPMIA has two Schools of Instruction per year so the members and contractors can receive some of the best training around and keep up

on their required hours needed to maintain their inspector's certifications and tradesman licenses through DHCD and DPOR. Also this year the following organizations, VPMIA and VBCOA, are planning another joint conference with outstanding training, with the common goal that uniformity is met throughout the state and the health, safety and welfare of all Virginia citizens is accomplished.

In closing, It has been a pleasure and great opportunity to serve as VPMIA President. I want to thank of the officers and directors and members who helped me make this a successful year. May we all continue to grow in knowledge and experience.

Thank you all,

Dennis Martinelli
President
VPMIA

— History —

**ORIGINAL HISTORY BY PAUL C. KING.
COMPILED FROM THE MINUTES OF THE
VPIA MEETING APRIL 14, 1962**

A small group...

of Virginia plumbing inspectors met in 1959 following a seminar at VPIA in Blacksburg. The group discussed the possibility of forming a statewide association for the purpose of dissemination of information touching on new methods, materials and testing procedures used in the plumbing and heating profession.

Following the three-day seminar the inspectors returned to their respective jobs. Being dedicated to their profession, these men contacted individual members of the Virginia State Master Plumbers Association meeting. Cards were mailed asking the inspectors if they were interested in forming such an association.

The first meeting of the group, which would be called The Virginia Plumbing Inspectors Association, took place April 14, 1962 at the Hotel John Marshall in Richmond. Attending were fourteen plumbing inspectors and three associate members. (These names are published as Charter Members.) The first order of business for the group was to name a temporary chairman, Mr. Mannion, followed by nomination and election of officers.

Officers elected were: President, Charles E. Mannion, Richmond; Vice President, Paul C. King, County of Fairfax; Secretary, John B. Mason, Richmond; Treasurer, James B. Jones, Jr., Martinsville; and Sgt. At Arms, E. R. Carr, Winchester. Board of Directors named included: U.E. Allen, Jr., Portsmouth; Frank B. Bosman, County of Arlington; and Gordon Dameron, Danville.

A committee consisting of inspectors King, Chairman, Carr and Cooper was appointed and instructed to draw up the proposed by-laws for the association. A general discussion followed covering the aims and purposes of the organization. A date was set for the

next meeting and the group adjourned its meeting to join the Master Plumbers Association, which was in session at this time.

By-Laws Adopted

VPIA met November 3, 1962 at 1014 East Broad Street, Richmond.

The By-Laws Committee presented its report, which was duly adopted. Article II of those by-laws set forth the purpose of the organization:

- A. Cooperate in the formulation of Virginia Plumbing Code Standards.
- B. Promote uniform understanding and application of all city, town and county plumbing codes.
- C. Secure and promote uniform administrative ordinances and inspection methods.
- D. Promote closer cooperation between inspectors, inspection departments, health departments, plumbing contractors and the public.
- E. Promote and improve the standards of the profession of plumbing inspectors.
- F. To institute and maintain a central organization to properly test new materials and methods to be used in this Commonwealth.

School of Instruction

The Association embarked on a program when Paul C. King served as proxy which has proven to be well accepted by those men serving in all phases of the plumbing industry. Known as "School of Instruction and Conference," the program owes its success to D. Paul Jack, Hampton. Through his efforts, almost single-handedly, Mr. Jack managed to obtain speakers from Texas, across the south, and as far west as Wisconsin. The first annual School of Instruction and Conference was held in Hampton on April 17 and 18, 1964 and was a huge success. Each succeeding year has found

the meeting generating more interest in the plumbing profession.

Inspectors have found that the annual school and conference has given us the opportunity to carry out some of the aims of VPIA, namely: "the dissemination of new methods and materials" on a state-wide basis. Our speakers are not only considered experts in their fields but they also present facts which help to generate enthusiasm among those association members interested in promoting the plumbing profession.

Executive Secretary

In 1969 the Board of Directors appointed an Executive Secretary with the responsibilities to direct the school for Qualified Plumbing Inspectors and to publish a newsletter for the purpose of keeping inspectors abreast with the workings of the association and other related items of interest that inspectors in Virginia and the southeastern states should be concerned with. Thus far the newsletter has accomplished its purpose and its present circulation includes eighteen states.

We are proud to be members of VPIA. The knowledge we have gained during the past years has made it possible for us to be cognizant that the plumbing profession is indeed one of the leading 'trades' in the building industry.

History Up-Date

In 1986, the Board of Directors instructed the committee on by-laws to update and revise the by-laws to meet and comply with the present day regulations. President John W. Thurston appointed Edward J. Baldwin, Jr., Chairman and D. Paul Jack as part of a two-member committee to study and propose the needed changes.

(continued on next page)

(History, continued)

On April 1988, at the Twenty-Fifth Annual School of Instruction as the yearly conference had now come to be known, after two years of study and consideration by the committee and board of directors, the amended by-laws were approved and adopted by the voting membership of the Virginia Plumbing Inspectors Association.

On July 21, 1990, at the Association's summer meeting, the voting membership of the Virginia Plumbing Inspectors Association voted unanimously to change the name of the Association to the Virginia Plumbing and Mechanical Inspectors Association. The change was felt necessary because of the number of jurisdictions within the Commonwealth of Virginia having separate mechanical inspection divisions whose inspectors were seeking educational opportunity. It was the feeling of the membership that this Association could provide that opportunity of educational instruction.

In-as-much as there were some other concerns regarding the by-laws, the Committee on By-Laws, consisting of Edward J. Baldwin, Jr., Chairman, Kenneth R. Snyder, Sr. and D. Paul Jack, Vice Chairmen, William F. Hines, Dennis W. McNaughton, Thomas C. Roberts and Paul M. Adams, Executive Secretary, was directed by President Robert M. Broome to study and submit amendments to the by-laws reflecting the name change and other necessary changes needed to include the mechanical personnel. Through the course of the study, an executive board, four regional directors positions and specific duties of the presidential appointed chairpersons were incorporated. The amended by-laws were approved by the committee on September 6, 1990 by the board of directors on October 6, 1990 and by the general membership in December 1, 1990.

After a period of working under the executive board, which consisted of the elected officers and the four regional directors, the board of directors instructed the Committee on By-Laws

to once again review and recommend any needed changes deemed necessary. This resulted in more changes being proposed, the most significant being a change in the fundamental membership and voting rules. The system used since the beginning of the Association was that of jurisdictional membership with a limit of one vote per jurisdiction. The proposed amendments included a change to individual membership with one vote per active member (associate members must remain without a vote in order to protect chapter membership in building officials and code administrations international).

The progress of these amendments, of the proposals and counter proposals, spanned the terms of three presidents and three by-laws committees. The first action of the general membership, which resulted in a change, was made on March 26, 1994 at the conclusion of the Thirty-First Annual School of Instruction. That change eliminated the executive board and dictated meeting schedules. Action was taken on June 25, 1994 which clarified the responsibilities of various officers and both board and presidential appointments. The action which resulted in the current by-laws was taken at the winter meeting on December 3, 1994.

During the course of the by-laws change process, another transition for our Association was under way. In the spirit of promoting closer cooperation between inspectors, inspection departments and plumbing contractors, the membership decided to hold the Twenty-Eighth Annual School of Instruction in Norfolk. The dates were April 11, 12, and 13, 1991 and this coincided with the annual meeting of The Virginia Cross Connection Control Association, The Virginia Association of Plumbing, Heating and Cooling Contractors, and the Richmond Chapter of The American Society of Plumbing Engineers. Although the various associations involved held their own separate educational and business meetings, the trade exposition, where new products and materials could be analyzed and

evaluated in a "hands-on" manner, was a central focal point. This cooperation has proven to be a successful format and continues with most of the same organizations being involved.

The Virginia Plumbing and Mechanical Inspectors Association was founded for the purpose of education and communication. As further evidence of this commitment, the annual summer meeting was expanded, beginning in 1994, to include a day of technical training. With the consolidation of BOCA, ICBO and SBCCI into the International Code Council and subsequent adoption of the International Codes in Virginia, the potential for growth has expanded and we have taken up the challenge. We continue to be a leader in the support of education and code development. In 2002 we received the BOCA Chapter of the Year Award for excelling in educational opportunities, membership and participation in BOCA activities. In 2004, we received the Directors Award from the Virginia Department of Housing and Community Development in recognition of our members' participation in the development and delivery of plumbing and mechanical code educational modules for the Virginia Building Code Academy as well as conducting statewide training in plumbing, mechanical and fuel gas code requirements and service on the Building Code Academy Advisory Committee. In 2005 the Association was honored to accept a Chapter Merit Award from the International Code Council.

Closer ties with our partners in code development and administration both within Virginia and throughout the country have developed. VPMIA, along with the Virginia Building and Code Officials Association and the Virginia Fire Prevention Association came together in October of 2005 for the first ever joint conference. The educational seminar lasted for four days with dual tracks offering a wide variety of training from Legal Aspects of Code Enforcement to Hydrogen Refueling Station installations. We

— VPMIA Charter Members —

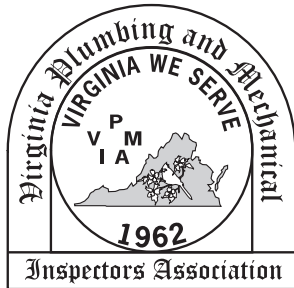

ACTIVE

- * MR. U. EARL ALLEN
- * MR. E. W. BAUGHAN
- MR. FRANK BOSMA
- * MR. E. R. CARR
- * MR. EUGENE COBANKS
- MR. M. D. COOPER
- * MR. GORDON I. DAMERON
- * MR. JAMES B. JONES, JR.
- * MR. PARL C. KING
- * MR. CHARLES E. MANNION
- * MR. JOHN B. MASON
- MR. CURTIS H. NUNALLY
- * MR. WILLIAM G. PRIDDY

ASSOCIATE

- * MR. JOSEPH E. BAKER
- * MR. T. C. BROWN
- * MR. CHARLES E. WESSMAN

LADIES AUXILIARY

- * MRS. RUTH BIANCO
- * MRS. ANN COBANKS
- * MRS. IRMA DRAKE
- MRS. RUTH JACK
- MRS. MARGARET KING
- MRS. SONIA SCHROECK
- MRS. SHIRLEY WILLIAMS

* Indicates Deceased

have strengthened our Association by focusing on our responsibilities and purpose. Our foundation now consists of a vision, a mission and a strategic plan to further our goals. Thus we go onward, not knowing what challenges are to be faced tomorrow, but confident that through our dedication to learning today, we will be prepared.

Making History

The VPMIA, VBCOA, VFPA Joint Conference
On October 21, 2005 the Virginia Plumbing and Mechanical Inspectors Association together with the Virginia Building Officials Association and the Virginia Fire Prevention Association held the first ever Joint Code Conference in Hampton, Virginia at Hampton's brand new Conference Center. The conference was a four day event that offered training in all areas of code enforcement. The Conference gave the participants an opportunity to



network with each other, develop code knowledge, and earn valued continuing education credits towards certification maintenance. The training, which included everything from Legal Aspects of Code Enforcement to Kitchen Exhaust Installations, was the center piece of the conference utilizing top trainers from around the country.

ICC CEO, James Lee Witt, former FEMA Director and ICC President Henry L. Green were on hand to install Officers and speak to the members. They spoke about the International Code Council Foundation that is helping the Gulf Region Code Officials that were devastated by the hurricanes last summer, get back on their feet. They also spoke regarding ICC's efforts to provide uniform codes for users nationwide. Mr. Witt is spearheading an effort called HEROS. It helps wounded war veterans retrofit their homes for handicapped accessibility as they return from war with devastating handicaps.

A table-top show, with manufacturers of building materials, computer systems and organizations such as ICC and UL were on hand to discuss their products and services. Several of the table-top vendors



also taught classes in their specialized areas. The ICC delivered a whole day class on the legal aspects of code enforcement which generated many questions from the class participants.

The social events were a big hit and well attended. On Saturday evening participants were treated to a buffet dinner and casino night at the Air and Space Museum, in Hampton. Everyone had a great time at the casino night and enjoyed the flight simulators. The next morning you had your choice of a golf outing or a fishing trip on the Chesapeake Bay. Although there weren't any hole in ones and very few fish were caught, everyone had a good time and took advantage of the opportunity to network.

Plans are being made for another joint conference in the future so be prepared to find yourself among the finest code enforcement officials in the state when we do it again.

VPMIA's most recent progress and achievements are detailed in the President's message, page 6.

— Program —



VP MIA 2008 School of Instruction

Wednesday, April 9

- 7:00 - 8:30 a.m. **REGISTRATION**
- 8:30 - 10:00 a.m. **INTERNATIONAL MECHANICAL CODE 2006 (4 Hrs)
AND INTERNATIONAL FUEL GAS CODE (2 Hrs)**
- 10:00 - 10:30 a.m. **BREAK**
- 10:30 - 12:00 p.m. **CLASS RESUMES**
- 12:00 - 1:00 p.m. **LUNCH**
- 1:00 - 2:30 p.m. **CLASS RESUMES**
- 2:30 - 3:00 p.m. **BREAK**
- 3:00 - 4:30 p.m. **CLASS RESUMES**
- 5:00 - 6:00 p.m. **PRESIDENT'S WELCOME**
- 6:00 - 7:30 p.m. **SOUTHERN BARBECUE**



Thursday, April 10

- 8:30 - 10:00 a.m. **INTERNATIONAL PLUMBING CODE 2006 FUNDAMENTAL CLASS**
- 10:00 - 10:30 a.m. **BREAK**
- 10:30 - 12:00 p.m. **CLASS RESUMES**
- 12:00 - 12:15 p.m. **VPMIA GENERAL MEMBERSHIP MEETING - PART 1**
- 12:00 - 1:00 p.m. **LUNCH**
- 1:00 - 2:30 p.m. **CLASS RESUMES**
- 2:30 - 3:00 p.m. **BREAK**
- 3:00 - 4:30 p.m. **CLASS RESUMES**
- 6:30 - 10:00 p.m. **BANQUET—AWARDS**



Friday, April 11

- 8:00 - 10:00 a.m. **GENERAL MEMBERSHIP MEETING - PART 2**
- 10:00 - 10:30 a.m. **BREAK**
- 10:30 - 12:00 p.m. **WELL & SEPTIC SYSTEMS**
- 12:00 - 1:00 p.m. **LUNCH WITH THE LADIES AUXILIARY**



Be sure to visit the TABLETOP PRODUCTS SHOW.
VP MIA offers its gratitude to the following Tabletop Exhibitors:

RMI, Inc
Cast Iron Soil Pipe Institute

DuctMate
NSF International

Sioux Chief
Thermal Ceramics

— Dedication —

VPMLA dedicates this Yearbook to **Jim Moore** for his dedicated service to the goals and mission of the organization. Jim has served selflessly for over 20 years by holding several different positions. These include: Plumbing Code Change Committee Chair, VPMLA BCAAC Representative for several years, Education Committee Chair, and served on the Virginia Regulatory Effectiveness Advisory Committee. Jim has also extended his services to other organizations: he has served as District Director and Regulatory Chairperson, and past President of the VCCCA. He was past BOCA representative on the CABO Plumbing Code Committee and member of the BOCA Code Interpretations Committee. Jim has always stepped up to the plate when asked to serve. He has been recognized for his participation in transforming the Virginia Building Code Academy's training from the traditional "reading sessions" to the current highly effective task-based, job-based training sessions they are today. His teaching experience was not only for the Code Academy, but also DHCD Code Update Training, Prince William Code Academy, Virginia Department of Health Backflow Prevention Schools, VPMLA, VCCCA, BOCA Annual Code Development and Educational Conference, PHCC, and PMPV of Virginia. His professionalism and hard work are good examples of why VPMLA is such a successful organization today.

— 2007-8 VPMIA Resolutions —



RESOLUTION

WHEREAS; That Guy Dupree Tomberlin, Sr. died on Wednesday, February 6, 2008, he was born on July 30, 1927,

WHEREAS; That Guy Tomberlin, Sr., is the Father of Active Member, Guy Tomberlin, Jr., a Past President of the Virginia Plumbing and Mechanical Inspectors Association (VPMIA) and remains an active Member of that Association,

WHEREAS; That Guy Tomberlin, Sr., served his beloved country During World War II in the United States Navy so serving for over thirteen years of active and reserve duty,

WHEREAS; That Guy Tomberlin, Sr., continued his career with Northwest Airlines at National Airport, Washington, D.C. and at the same time was a part time employee of A&P Food Stores for 25 years, and,

WHEREAS; That Guy Tomberlin, Sr., was a man with a caring heart, who enjoyed life and loved people; he lived his life with integrity and bravery. He was a member of the Kena Shrine and the Freemasons, both private fraternal associations for men, now therefore be it

RESOLVED; That the Officers, Board of Directors, and the entire Membership of the Virginia Plumbing and Mechanical Inspectors Association join Guy and his family in the celebration of his Father's life but also offer their most heartfelt sympathy at the loss of this cherished family member,

RESOLVED; That the Virginia Plumbing and Mechanical Inspectors Association stands in readiness to assist the family of Guy D. Tomberlin, Sr., in any manner desired or requested, and

RESOLVED; That this Resolution be published in the annual Virginia Plumbing and Mechanical Inspectors Association Newsletter as a permanent memorial to the memory of Guy D. Tomberlin, Sr.

Most sincerely submitted,

Attest:
JOHN W. MILLS
Vice President

Approved:
DENNIS MARTINELLI
President

RESOLUTION



WHEREAS; Gerritt W. Fitzgerald passed away at home in Grass Lake, Michigan on January 17, 2008,

WHEREAS; That Gerritt W. Fitzgerald, is the Father-in-Law of Active Member, Ronald M. Bladen, Chairman, Yearbook and Advertising Committee and current Director, District 1 of the Virginia Plumbing and Mechanical Inspectors Association (VPMIA), and Father of Jane E. Fitzgerald (Bladen), current President, VPMIA Ladies Auxiliary, and

WHEREAS; That Gerritt W. Fitzgerald, served his beloved country as a B-17 pilot in the United States Army Air Corps, retiring as Captain, and

WHEREAS; That Gerritt W. Fitzgerald, served, originally with the U.S. Public Housing Administration and later as Senior Department Director for the U.S. Department of Housing and Urban Development, now therefore be it,

RESOLVED; That the Officers, Board of Directors, and entire Membership of the Virginia Plumbing and Mechanical Inspectors Association join Ron and his family in the celebration of his Father-in-law's life but also offer their most heartfelt sympathy at the loss of this cherished family member,

RESOLVED; That the Virginia Plumbing and Mechanical Inspectors Association stands in readiness to assist the family of Gerritt W. Fitzgerald, in any manner desired or requested, and

RESOLVED; That this Resolution be published in the annual Virginia Plumbing and Mechanical Inspectors Association Newsletter as a permanent memorial to the memory of Gerritt W. Fitzgerald.

Most sincerely submitted,

Attest:
JOHN W. MILLS
Vice President

Approved:
DENNIS MARTINELLI
President



Virginia Plumbing & Mechanical Inspectors Association

Foundation's Vision Statement

VPMIA members are committed to providing code development leadership and continuous training that results in uniform application of the codes. We look for opportunities to partner with all who are impacted and strive to develop and deliver codes and standards that result in health, safety, and welfare protection for the public.

Mission

VPMIA is an association of code professionals dedicated to promotion of uniform enforcement and development of the codes throughout the Commonwealth to assure the health, safety, and welfare of its citizens and any one who may live, work, or visit the state of Virginia. The pursuit of this endeavor is achieved through close, open, and equal working relationships with design professionals, builders, contractors, material manufacturer's and others involved in the construction industry. VPMIA supports the ICC, its goals and mission.

Strategic Plan Mission

VPMIA's strategic plan is to advance our mission through training in order to promote better understanding of the benefits and efficiency of using model codes. The association promotes teamwork, while embracing fairness and respect to all involved parties, always maintaining open communications in every aspect to those who participate in the process.

CODE OF ETHICS

We the members of Virginia Plumbing and Mechanical Inspectors Association recognize that our work has a direct and vital impact on the quality of life for all people in the Commonwealth of Virginia, and we are dedicated to the highest standards of professionalism, integrity and competence. We therefore pledge to maintain and advance these ethical principles:

- Place the public safety and health above all other interests and recognize that the primary function of government is to service the best interests of all people.
- Consider my profession a distinct opportunity to serve society.
- Demonstrate integrity, honesty and fairness in the discharge of my duties by striving to achieve excellence in all matters of ethical conduct.
- Treat all persons courteously, equally and fairly.
- Conduct myself at all times in such a manner as to create and maintain respect for the Virginia Plumbing and Mechanical Inspectors Association and the industry it represents.
- Refuse to leverage my position to secure advantage of favor for myself, my family or my friends.
- Neither accept nor offer, any gift, favor or service that might tend to influence me in the discharge of my professional duties.
- Refrain from representing private interests in any business or technical affairs of this Association
- Use every opportunity to improve public understanding of the Virginia Plumbing and Mechanical Inspectors Association and its important contribution to the Commonwealth of Virginia.
- Maintain loyalty to the Virginia Plumbing and Mechanical Inspectors Association, and pursue its objectives in ways that are consistent with the public interest.

— Constitution & By-Laws —

VIRGINIA PLUMBING AND MECHANICAL INSPECTORS ASSOCIATION

ARTICLE I — The Name, Seal, and Address of this Association

Section 1. The name shall be the Virginia Plumbing and Mechanical Inspectors' Association; herein and hereafter referred to as the Association.

Section 2. The seal shall be as indicated below:

Section 3. The address shall be that of the Executive Secretary or as otherwise designated by the Board of Directors.

ARTICLE II — Objectives

Section 1. The objectives of the Association are:

- A. To participate in the formulation of Virginia Plumbing and Mechanical Code provisions.
- B. To promote uniform understanding and application of the Virginia Uniform Statewide Building Code.
- C. To promote and secure uniform inspection methods throughout the Commonwealth of Virginia.
- D. To promote closer industry unity between code officials, governing agencies and the private sector.
- E. To promote and improve the standard of professional plumbing and mechanical inspectors.
- F. To provide professional development through an annual education and training seminar which shall be known as the School of Instruction.
- G. To encourage growth of the Association by providing enhanced services to its members and by promoting strong leadership values, respect and the pursuit of common goals.

ARTICLE III — Membership

Section 1. Active membership shall be open to code officials actively engaged in plumbing and/or mechanical code enforcement. Application for membership shall be in writing and submitted to the Executive Secretary.

Section 2. Associate membership shall be open to those persons interested in the design, manufacture, installation or sale of plumbing and/or mechanical systems and who are willing to promote the objectives of the Association. Application for membership shall be in writing, submitted to the Executive Secretary and reviewed by the Board of Directors for approval.

Section 3. Retired membership shall be open to those members submitting written application for retired status to the Executive Secretary.

Section 4. Life membership may be extended only to Active and Associate members who have significantly contributed to promoting the objectives of the Association. Life members may be nominated and approved by the general membership at the third general membership meeting. Life membership shall be limited to one Active member and one Associate member per calendar year.

Section 5. Charter members are those who founded the Association.

Section 6. Honorary membership shall be open to those persons who are not members of the Association but have made a significant contribution in promoting the objectives of the Association. Nominations for Honorary membership shall be in writing, submitted to the Executive Secretary by any member and reviewed by the Board of Directors for approval.

Section 7. All members shall conduct themselves in accordance with the Associations Code of Ethics.

ARTICLE IV — Board of Directors

Section 1. The Association shall be governed by a Board of Directors, herein and hereafter referred to as the Board, which shall consist of the elected officers, District Directors Committee Chair Persons and the Director-at-Large.

Section 2. The Board shall manage the policies, business, property and affairs of the Association.

Section 3. Officers

- A. The officers of the Association shall consist of a President, Vice President, Secretary and Treasurer. The officers shall be Active members and shall be elected and installed during the annual School of Instruction.
- B. The officers shall hold office from the close of the annual School of Instruction through the close of the annual School of Instruction of the following year. Officers shall serve no more than two consecutive terms in the same office.

Section 4. Directors

- A. A total of eight Active members may be elected as District Directors. The Directors shall be Active members and shall be elected and installed during the annual School of Instruction.
- B. The Directors shall hold office from the close of the annual School of Instruction through the close of the annual School of Instruction the following year.
- C. Each District shall consist of all cities, towns and counties as outlined in Appendix A.
- D. The Director-at-Large shall be the immediate Past President.
- E. Non-voting Ex-officio members on the Board of Directors shall include the President, or his or her duly appointed representative, of the Virginia Chapter of the International Association of Electrical Inspectors, The Virginia Fire Prevention Association, and The Virginia Building Code Officials Association.

Section 5. In the event that an Officer or Director resigns, the Board shall appoint, as soon as possible, an Active member to fill the unexpired term.

Section 6. Appointments



- A. An Executive Secretary shall be appointed by the Board for a maximum term of five years or as determined by the Board. Compensation of services rendered shall be as approved by the Board.
- B. A Director of Finance shall be appointed by the Board for a maximum term of five years or as determined by the Board. Compensation of services rendered shall be as approved by the Board.

ARTICLE V — Duties of the Officers, Directors, Executive Secretary and Finance Director

Section 1. The President

- A. To preside over all meetings.
- B. To select all committee chairpersons except the finance and the nominating committees.
- C. The President may appoint members to represent the Association on local, state or national committees, boards and similar entities when such representation is requested or provided for by regulation or statute. Appointments shall not conflict with the Association's By-laws or code of ethics.
- D. To be an ex-officio member of all committees except the nominating committee.
- E. To perform such other duties applicable to the office as prescribed by the parliamentary authority adopted by the Association.

Section 2. The Vice President

- A. To assist the President at all meetings.
- B. To preside over all meetings in the absence of the President.
- C. To perform such other duties as applicable to the office as prescribed by the parliamentary authority adopted by the Association.

Section 3. The Secretary

- A. To assist the presiding officer with the orders of business and to distribute correspondences to all members present.
- B. Notification of meetings.
 - 1. To send to all Board members a notice of every Board meeting at least twenty days in advance of such meeting
 - a. Ten days notice, including an agenda, shall be given for all special meetings.
 - 2. To send all members a notice of every General Membership meeting at least thirty days in advance of such meeting.
- C. To accurately record all business transacted at all meetings.
- D. To maintain and have available at all meetings the

official minute book.

- E. To record the voting at all meetings.
- F. To send letter ballots to all Board members not present at meetings for which there is no quorum.
- G. To perform such other duties as applicable to the office as prescribed by the parliamentary authority adopted by the Association.

Section 4. The Treasurer

- A. To accurately record and post all funds received and disbursed. Shall be bonded for at least fifty thousand dollars. The bond premium shall be paid by the Association.
- B. To pay all bills that have been approved as per the budget or by the Board.
- C. To submit a quarterly report of the Association's finances to the Finance Committee.
- D. To submit a report of the Association's finances at all meetings, except special meetings unless included in the special meeting agenda.
- E. To send all membership renewals by December 1 of each year.
- F. To maintain the financial records of the Association on a fiscal year from May 1 through April 30, unless otherwise approved by the Board.
- G. To be a standing member of the Finance Committee.
- H. To perform such other duties as applicable to the office as prescribed by the parliamentary authority adopted by the Association.

Section 5. The District Director

- A. To attend at least two Board meetings per term of office.
- B. To assist in the management of the Association.
- C. To report any concerns of the members within their district to the Board.

Section 6. The Executive Secretary

- A. To prepare for the Board all business that has not been assigned to others.
- B. To present or have presented at all meetings all reports received from committee chairpersons.
- C. To recommend plans of work and conduct the general business of the Association under the direction of the Board and the General Membership.
- D. To be a standing member of the School of Instruction Committee.
- E. To authorize both active and/or retired membership status.

Art. V, continued

Art. V, continued

- F. To maintain all membership applications.
- G. To receive the letter of resignation of an Officer or Director and present it at the next Board meeting.
- H. To send to each Director a current roster of all members within their respective districts no more than thirty days after the third General Membership meeting.
- I. To maintain and have available at all meetings a current roster which lists only members in good standing by district affiliation.

Section 7. The Director of Finance

- A. To coordinate the finances of the Association.
- B. To serve as the chairperson of the Finance Committee.

ARTICLE VI — Committees

Section 1. The number of committee members, mentioned below, includes the chairperson. Committee chairpersons are appointed by the President, see previously in the text, Article V,

Section 1.B. Committee members are selected by the committee chairperson as stated hereinafter in this Article or are established within the description of the committee. Committee members that are established by the text are in addition to those members appointed and selected. Committees may include, but not limited to. The following:

Section 2. An Advertising and Yearbook Committee, composed of five members, shall be appointed within thirty days after the third General Membership meeting. It shall be the duty of this committee to manage an advertising campaign and publish the yearbook for the Association's School of Instruction.

Section 3. An Auditing Committee, composed of three members, shall be appointed within thirty days after the third General Membership meeting. It shall be the duty of this committee to audit the Treasurer's account(s) at the close of the calendar year and report at the fourth regular Board meeting. The Treasurer shall not be a member of this committee.

Section 4. An Awards Committee, composed of five members, shall be appointed within thirty days after the third General Membership meeting. It shall be the duty of this committee to select and present, the awards for Outstanding Service to the Active and Associate members of the Association and the awards to the individuals that are the outstanding plumbing and mechanical apprentice of the year.

Section 5. A By-laws Committee, composed of five members, shall be appointed within thirty days after the third General Membership meeting. It shall be the duty of this committee to review, discuss, prepare and recommend, to the Association, any necessary changes to the Association's By-laws in order to maintain current directives for the administration of the Association.

Section 6. A Certification, Education, and Training Committee, composed of five members, shall be appointed within thirty days after the third General Membership meeting. It shall be the duty of this committee to organize educational classes for the School of Instruction.

Section 7. A Finance Committee, composed of three members, the Treasurer and the Finance Director, shall be appointed within thirty days after the third General membership meeting. It shall be the duty of this committee to prepare a budget for the fiscal year and submit it to the Board for approval at its last scheduled meeting prior to the third

General Membership meeting. The committee may submit amendments to the current budget at any regular meeting. The committee shall prepare and submit any other reports as directed by the Board.

Section 8. A Legislative Committee, composed of three members, shall be appointed within thirty days after the third General Membership meeting. It shall be the duty of this committee to attend as many Virginia General Assembly meetings as possible and to be observant of new regulations. This committee will review, discuss and report to the Board of Directors and the General Membership, any legislature or regulations that will directly or indirectly effect the Association or its members.

Section 9. A Mechanical & Fuel Gas Code Committee, composed of all Association members willing to participate, the chairperson shall be appointed within thirty days after the third General Membership meeting. It shall be the duty of this committee to review, discuss and recommend necessary changes that apply to the Mechanical Code and the Fuel Gas Code.

Section 10. A Membership and Website Committee, composed of five members, shall be appointed within thirty days after the third General Membership meeting. It shall be the duty of this committee to keep the website current and updated. The website shall be the source of Association meetings, dates, membership and advertisement applications, Association and public information and other Association information.

Section 11. A Nominating Committee shall be composed of the five most immediate past presidents of the Association willing to serve in this capacity. The most immediate past president on the committee shall serve as the chairperson. It shall be the duty of this committee to nominate, at the third General Membership meeting, candidates for the offices to be filled. Before the election, additional nominations from the floor shall be permitted.

Section 12. A Plumbing Code Committee, composed of all Association members willing to participate, the chairperson shall be appointed within thirty days after the third General Membership meeting. It shall be the duty of this committee to review, discuss and recommend necessary changes that apply to the Plumbing Code.

Section 13. A School of Instruction Committee, composed of three members, the Executive Secretary, the chairpersons of the Time and Place Committee and the Certification, Education and Training Committee, shall be appointed within thirty days after the third General Membership meeting. It shall be the duty of this committee to plan the program for the next Annual School of Instruction.

Section 14. A Special Committee, composed of five members, shall be appointed for a specific purpose, when necessary. It shall be the duty of this committee to carry out a specified task and present a report to the Board.

Section 15. A Time and Place Committee, composed of five members, shall be appointed within thirds after the third General Membership meeting. It shall be the duty of this committee to review the date and location of all General Membership meetings and submit a report and recommendation to the General membership for approval at least twelve months prior to such meeting.

Section 16. Committees shall be under the authority and direction of the Board, unless specifically provided for herein.

Section 17. Duties of the Committee Chairperson

- A. To submit, in writing, all committee findings and recommendations to the Executive Secretary at least ten days prior to any meeting, except special meetings, unless specified on the agenda. If the

chairperson or members of the committee is in attendance at the meeting, such written report shall not be required.

- B. To select all committee members not specifically provided for in other sections of these by-laws and report their names to the Executive Secretary within thirty days of their appointment.

ARTICLE VII — Voting

Section 1. Only Active, Charter and Lifetime Active members who are in good standing shall have the right to vote.

Section 2. All members shall have the right to make and second motions.

ARTICLE VIII — Meetings

Section 1. Three General Membership meetings shall be held each year. The first shall take place approximately fourteen days prior to or fourteen days after August 1. The second shall take place approximately thirty days prior to or thirty days after November 15. The third shall take place approximately fourteen days prior to or fourteen days after April 1, during the Annual School of Instruction.

Section 2. Four Board meetings shall be held each year at a time and location determined by the President. The first shall be held at least sixty days prior to the first General Membership meeting. The second shall be held at least sixty days prior to the second General Membership meeting. The third on the day of the second General Membership meeting and the fourth at least thirty days prior to the third General Membership meeting. A quorum shall consist of at least seven Board members. Action taken by less than seven Board members shall be null and void unless confirmed by a letter ballot from those members who were absent.

Section 3. Special Board meetings may be called by the President. Such meetings may also be called by the Board with the written request of at least seven members. The purpose of the meeting shall be stated in the call. The location of the meeting shall be determined by the President. At least ten days notice shall be given. A quorum shall consist of at least ten Board members. Action taken by less than ten Board members shall be null and void unless confirmed by a letter ballot from those members who were absent.

ARTICLE IX — Dues

Section 1. Annual Dues

- A. Active membership shall be thirty dollars per calendar year.
- B. Associate membership shall be thirty-five dollars per calendar year except those who have paid for five consecutive years shall only be required to pay thirty dollars per consecutive calendar year thereafter.
- C. Retired membership shall be ten dollars per calendar year.
- D. Charter and Life membership shall be absorbed by the Association.

Section 2. No members shall be in good standing whose dues are not paid by March 1 of each year and shall not be maintained on the

membership roster if not paid by December 31.

Section 3. Dues may only be revised at General Membership meetings.

— Ladies Auxiliary —

Ladies,
You are invited to join us—our activities are
**OPEN TO ALL SPOUSES ATTENDING THIS
CONFERENCE**

Why not become an Auxiliary member?
Annual Dues \$10 — payable at registration

2008 Program Schedule

Wednesday, April 9

7:00 – 8:30 a.m.	REGISTRATION (Ladies Auxiliary)	Lobby
11:00 – 2:00 p.m.	Kluge Art Museum tour and LUNCH out (informal)	Meet in Lobby
2:00 – 4:30 p.m.	Craft or Bingo	Hospitality Room
5:00 – 6:00 p.m.	PRESIDENT'S WELCOME	Banquet Room
6:00 – 7:30 p.m.	Bar B Q Dinner	Banquet Room

Thursday, April 10

7:30 – 9:00 a.m.	REGISTRATION	Lobby
9:00 – 11:30 a.m.	CRAFT	Hospitality Room
11:30 – 1:30 p.m.	LUNCHEON and BUSINESS MEETING	Meet in Lobby Local Restaurant
1:30 – 4:30 p.m.	SHOPPING	
6:00 – 10:00 p.m.	BANQUET, AWARDS, INSTALLATION OF OFFICERS	Banquet Room

Friday, April 11

7:30 – 8:30 a.m.	REGISTRATION	Lobby
9:00 – 11:30 a.m.	BINGO	Hospitality Room
12:00 – 1:00 p.m.	LUNCH VPMIA & Ladies	Banquet Room

The VPMIA Ladies Auxiliary is an ancillary group to VPMIA. Its purpose is to act as an assistant and a support to the Association's endeavors to provide code development leadership and continuous training that results in uniform application of the codes.

This group is also about having fun along the way.

Join us in Charlottesville. We will conduct our annual luncheon/business meeting and get to know each other better during some scheduled events: exploring items of local interest, some friendly games of Bingo and a craft activity. These informal activities are scheduled to take place while the VPMIA meetings and School of Instruction are in session—leaving time to socialize with the full VPMIA group during lunches and dinners.

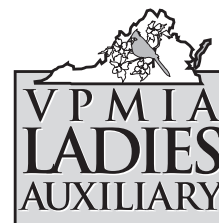

Membership Roster as of March 2008

Jane Fitzgerald (President)
VPMIA (Ron Bladen)
5716 North 7th Street
Arlington, VA 22205
703-527-4210 (H)
703-527-1238 (W)
msfitz13@verizon.net

Mary Thuot (Vice President)
VPMIA (Michael)
3197 Adam Keeling Road
Virginia Beach Va 23454
757-496-0355.
mthuot2686@aol.com

June Seay (Secretary/Treasurer)
VPMIA (John)
280 Coles Rolling Road
Scottsville, VA 24590
434-286-3139
jws5z@virginia.edu
seayit2@yahoo.com

Connie Hines
VPMIA (Bill)
4086 Stanberry Avenue
Marshall, VA 20115
540-364-2934

Sherry D. Rimel
VPMIA (Paul)
1159 New Hope Road
Staunton, VA 24401
540-248-6627 (H)
540-332-7086 (W)
rimelsd@comcast.net

Ethel Showman
(Past President)
VPMIA (Geary)
1221 St. Luke Road
Woodstock, VA 22664
540-459-2789
eshowman@shentel.net

Sandy Tomberlin
VPMIA (Guy)
1358 Ebenezer Road
Bluemont, VA 20135
540-554-2765 (H)
703-324-1817 (W)
sandytomberlin@msn.com



L.A. Lacy, Inc.

Commercial and Industrial Design Build Mechanical Contractor
Celebrating 85 years of Quality!
www.lalacy.com

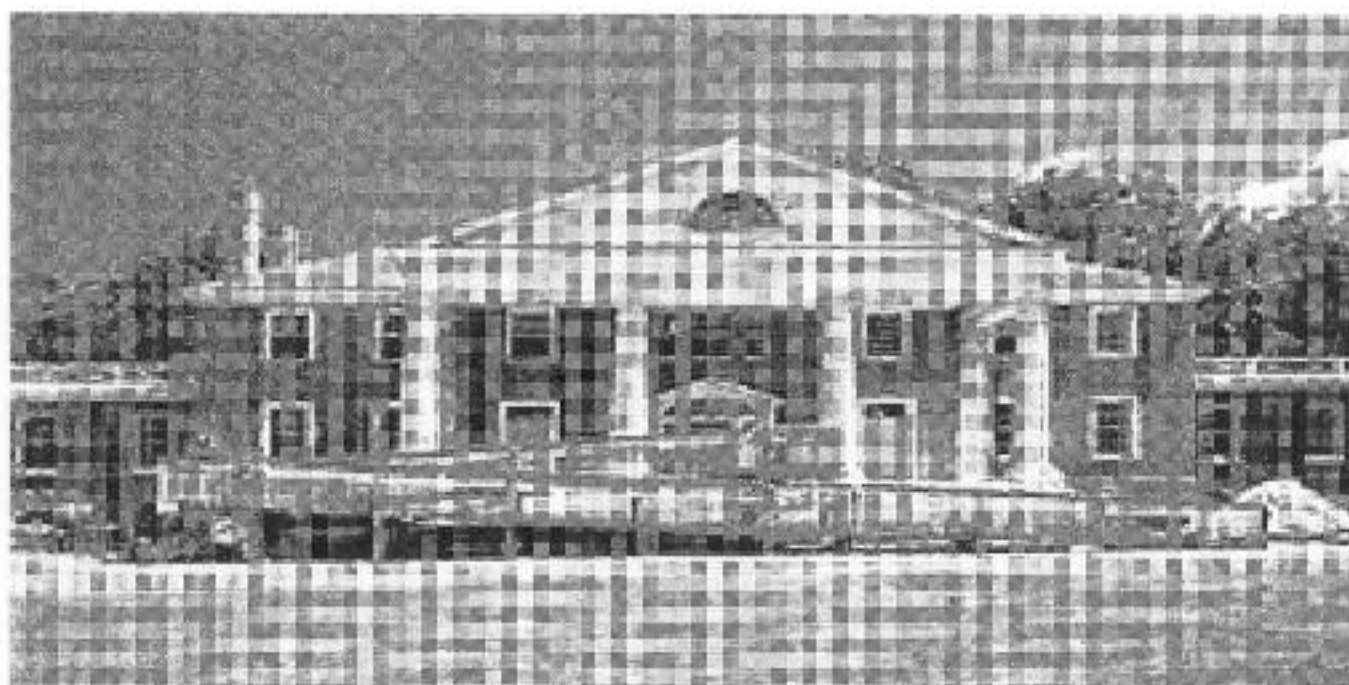

Proud participant in the James Madison Montpelier Restoration Project

900 Harris Street
Charlottesville, VA 22903

Phone: 434.296.7542
Fax: 434.293.9073



VPMIA Awards Roster

OUTSTANDING SERVICE

Gordon I. Dameron Active Award

1981-1982	Kenneth R. Synder, Jr.
1982-1983	Jesse R. Hurt
1983-1984	George H. Williams, Jr.
1984-1985	Robert M. Broome
1986-1987	Paul M. Adams
1988-1989	Paul Hostetler Joseph Hall
1989-1990	Dennis W. McNaughton
1990-1991	Floyd Proffitt
1991-1992	Jeffrey Shawver
1992-1993	Tommy Cantrell
1993-1994	Hassel E. DeShazo
1994-1995	Doug Stover Jack Rhoden
1995-1996	Robert D. Carroll
1996-1997	Roy N. McFarland, Jr.
1997-1998	Kathleen T. Dye
1998-1999	_____
1999-2000	Michael D. Thuot
2000-2001	Guy Tomberlin
2001-2002	John B. Seay, Jr.
2002-2003	Dennis Martinelli
2003-2004	Geary Showman
2005-2006	Wayne Kushner

David L. Carr Associate Award

1981-1982	William E. Foley
1982-1983	John V. Duley
1983-1984	J. C. Nuckols
1984-1985	Lawrence R. Muse
1986-1987	David Maupin
1987-1988	Ronald Bryant
1988-1989	Robert W. Price
1989-1990	Fred Borden, Jr.
1990-1991	Billy E. Leeder
1992-1993	James B. Muncy
1993-1994	John Otto
1994-1995	Danny & Laurie Crigler
1995-1996	James B. Hylar
1996-1997	J. C. Nuckols
1997-1998	James S. Steinle
1998-1999	Thomas C. Roberts
1999-2000	David Johnston
2000-2001	David L. Maupin
2001-2002	Lorrie Norton
2002-2003	Allen Tryall
2003-2004	Jonathan Sargeant
2005-2006	David Maupin



VPMIA Past Presidents

CHARLES E. MANNION	1963*
PAUL C. KING	1964*
GORDON I. DAMERON	1965*
D. PAUL JACK	1966*
FRANK B. BOSMA	1967
U. EARL ALLEN	1968*
HARRY CONTE	1969
JAMES B. JONES	1970*
L. W. FURMAN	1971
GEORGE H. WILLIAMS	1972*
W. T. DRAKE	1973*
BENJAMIN BIANCO	1974
J. L. SHIFFLETT	1975
HOMER O. DENNIS	1976
JULIAN E. MEREDITH	1977
EDWARD T. PARSONS	1978*
EDWARD J. BALDWIN, JR.	1979
HENRY A. RODÉS	1980*
RUDOLF SCHROECK	1981
JESSE R. HURT	1982
CHARLES DEDIAN	1983
KENNETH R. SNYDER, SR.	1984
LAWRENCE J. NUCKOLS	1985
JOHN W. THURSTON	1986*
WILLIAM F. HINES	1987
LESLIE A. COURTNEY	1988
JIMMY A. ENGLISH	1989
DOUGLAS L. STOVER	1990
ROBERT M. BROOME	1991
PAUL D. HOSTETLER	1992
DENNIS W. McNAUGHTON	1993
JOHN S. TRENARY	1994
MICHAEL D. REDIFER	1995/1996
KATHLEEN T. DYE	1997
HASSEL DeSHAZO	1998
ROY N. McFARLAND, JR.	1999/2000
CLEATIS DYE, JR.	2001
CHARLES GERBER	2002
GUY TOMBERLIN	2003/2004
GEARY SHOWMAN	2005
MICHAEL THUOT	2006
JOHN SEAY	2007

*Denotes deceased

LIFETIME MEMBERSHIP

D. Paul Jack Active Award

1988-1989	Edward J. Baldwin, Jr.
1989-1990	George H. Williams, Jr.
1990-1991	Kenneth R. Snyder, Jr.
1991-1992	Jesse R. Hurt
1992-1993	Douglas Stover
1993-1994	Ernest "Bud" Lester
1994-1995	Paul Hostetler
1995-1996	Paul M. Adams
1996-1997	Michael D. Redifer
1997-1998	Hassel E. DeShazo
1998-1999	Kathleen T. Dye
1999-2000	_____
2000-2001	William F. Hines
2001-2002	Larry Dehaven
2002-2003	Lawrence Nuckols
2003-2004	Roy McFarland, Jr.
2004-2005	Guy Tomberlin
2005-2006	Stephen P. Borders

John A. Otto Associate Award

1988-1989	Cecil F. Hardee, Sr.
1989-1990	J. Richard Maher
1990-1991	David L. Carr
1991-1992	Robert W. Price
1992-1993	_____
1993-1994	Billy E. Leeder
1994-1995	James B. Muncy
1995-1996	Thomas C. Roberts
1996-1997	Tom Kreutzer
1997-1998	James S. Steinle
1998-1999	John Otto
1999-2000	_____
2000-2001	Herbert L. Joyner
2001-2002	Laurie/Danny Crigler
2002-2003	Dave Johnson
2003-2004	_____
2004-2005	_____
2005-2006	_____

Bright futures for skilled craftsmen

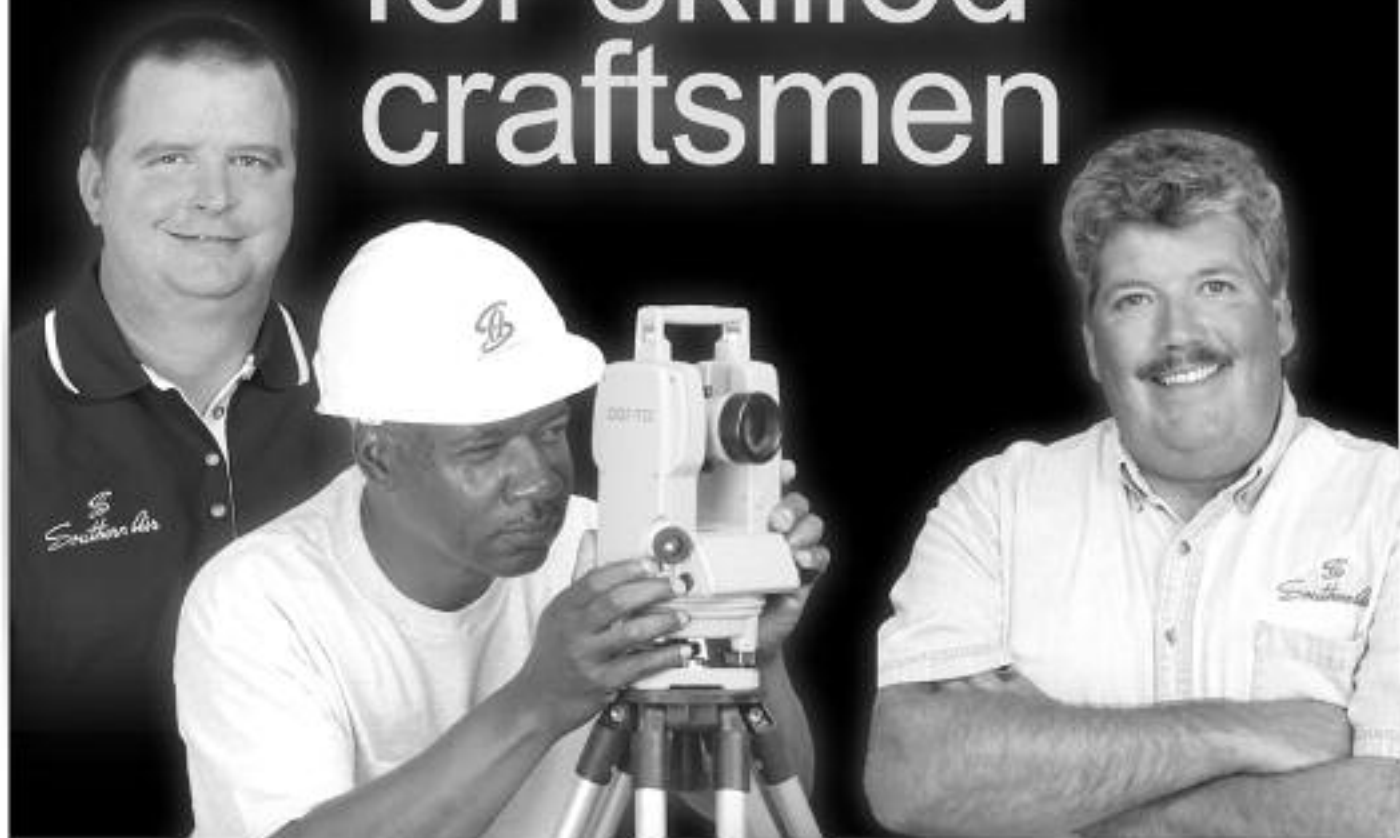

Southern Air

Electrical • Plumbing • HVAC

800/743-1214

Quality Sales & Service
Since 1924

Virginia Registration
#2701005193A



SERVICE TODAY
W. E. Brown, Inc.

Plumbing - Heating - Air Conditioning - Electrical
915 Monticello Road • Charlottesville, VA 22902
24 Hour Emergency Service

Dave Maupin
(434) 951-8712
dave@webrown.com

PH (434) 295-1177
FAX (434) 979-1394
1-800-W E Brown

—From Ron Bladen, Chairman—
VPMIA Advertising/Yearbook Committee

Thank You
to the 2008 VPMIA YEARBOOK Contributors

Dennis Martinelli
President, VPMIA

Jane Fitzgerald
Fitzgerald Art & Design LLC

John Seay
Past President, VPMIA

Don Bladen
VMW Printing

Gearry Showman
Executive Secretary, VPMIA

Our Advertisers
Individually listed on page 5

with special thanks to
*Jay Peters and Lee Clifton, International Code Council, and
Wes Davis, Air Conditioning Contractors of America*

— Strategic Plan —

GOAL # 1

— Enhance and increase communications of VPMIA with the public (Communications)

Initiative action:

- Actively promote a positive image of code enforcement's role in the community.
- Advertisements in trade, industry, state DHCD, and community publications.
- Commitment to code development to achieve the superior level of health, safety, and welfare for our citizens.

GOAL # 2

— Increase and expand education (Training — Communications)

Initiative action:

- Encourage increased participation from all interested parties who interact with any and all aspects of code enforcement.
- Increase awareness of the educational benefits of the association.
- Promote credentialing programs provided by the state DHCD.

GOAL # 3

— Uphold the highest levels of professionalism (Leadership — Professionalism)

Initiative action:

- Instill and promote leadership values.
- Always display integrity.
- Adherence to code of ethics.
- Share knowledge at all levels.
- Maintain and promote certifications.
- Respect others.

GOAL # 4

— Promote relationships with industry and related professional organizations (Cooperation)

Initiative action:

- Participate in the code development process.
- Encourage cooperative working relationships with construction-industry professionals.
- Become involved as active or associate members to other professional organizations such as VBCOA, ICC, VCCCA, IA EI, and PMPV.
- Solicit speakers and provide speakers for these organizations to enhance communication.
- Continue to actively participate in DHCD towards uniform application and development of the model building codes and standards.

GOAL # 5

— Broaden and expand VPMIA Membership (Membership)

Initiative action:

- Develop information package of the organization benefits.
- Provide more member services.
- Develop a more wide spread advertisement program for membership, including associate members.

GOAL # 6

— Continue leadership and participation in code development process (Leadership — Code Development)

Initiative action:

- Enhance and develop strategies for participation in International Code Council Code developmental process.
- Encourage participation on state and national committees.
- Provide financial support towards member participation in these activities.

GOAL # 7

— Promote the adoption of the International Code Council family of model codes (Communications — Training)

Initiative action:

- Provide analysis and impact of benefits for industry, where necessary.
- Provide training for code enforcement officials and industry.
- Interact with DHCD to provide uniform enforcement of model codes.

GOAL # 8

— Ensuring financial viability of VPMIA

Initiative action:

- Align financial resources to organizational outcomes.
- Achieve goal objectives.
- Operate within budgeted plan.

— Upcoming Events —



Summer School of Instruction

**Thursday and Friday
August 7-8, 2008
Graves Mountain Lodge**

Training, Meeting and Picnic

YOU can participate in VPMIA
throughout the year.

Attend Board of Directors Meetings (4 meetings) and General Membership meetings (3 meetings) throughout the year, check for the most current times and location information on the VPMIA web site at www.vpmia.org

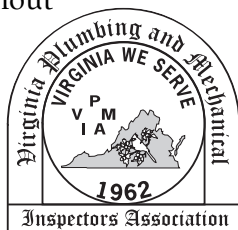

Be part of the 2008 JOINT CONFERENCE

VPMIA and VBOCA have finalized plans for a Joint Conference to be held October 26-29, 2008 in Wytheville, VA.

Additional details will be available soon. Check either association website for updates and other information.



*Some leaks are beautiful, as they are;
for the rest, call...*

the plumbing dr



Fully licensed, bonded and insured — 24 hour emergency service

*Complete Plumbing Repairs
Remodeling, Sewer & Drain Cleaning*

Family Owned and Operated for over 25 Years

The Plumbing Dr. has been honored by **Washingtonian Magazine** and **Consumer Checkbook** as one of the top-rated plumbing services in the region.

1063-B W. Broad Street • Falls Church, VA 22046
Phone: 703.525.9280 • www.theplumbingdr.com

WARDFLEX™ CSST

When choosing a CSST system for natural gas or propane...
 Choose experience. Choose **WARDFLEX™**
 The **ONLY CSST with a LIFETIME WARRANTY...!**



Elkhart Products Corporation

www.elkhartproducts.com

QTITE™

WORK QUICK. WORK SMART.

A permanent Wrot Copper Push-to-Connect System for Copper, CPVC & PEX



TECTITE™

A Removable Brass Push-to-Connect System for Copper, CPVC & PEX - **NOW UP TO 2"**



XPRESS™

THE FASTER FIT.

Simple, clean, efficient joining method that improves the joining process & speeds up installation
SAVING SIGNIFICANT TIME & MONEY.



MODINE | APPLIED THERMAL INNOVATION™



Modine is the leader in design, engineering & manufacturing of heating, ventilating & air-conditioning equipment. We provide unit, infrared and cabinet heaters and fin-tube radiators for commercial, agricultural & industrial markets. Looking for the perfect solution for heating up your garage, workshop or greenhouse? Then check out our low-profile **HOT DAWG®**.

Represented by...  **Harry Eklof & Associates, Inc.**

3401 Pennsy Drive • Landover, MD 20785 • 800-556-7556 • 301-772-1700 • Fax 301-772-7347
www.harryeklof.com E-mail: info@harryeklof.com

The International Plumbing Code

Protecting the Environment

Lee Clifton

Director of Plumbing Programs
Plumbing, Mechanical and Fuel Gas (PMG)
International Code Council

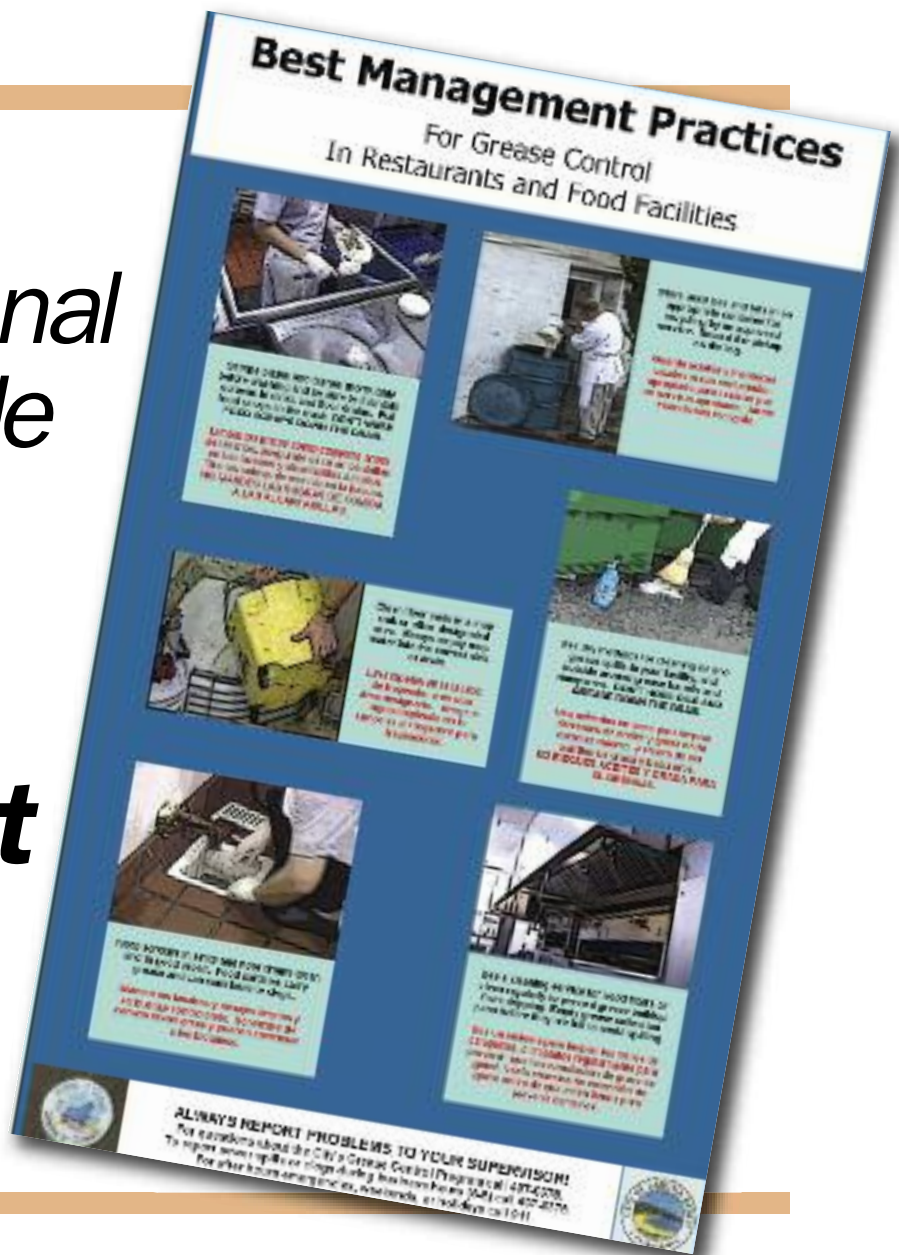

The Environmental Protection Agency (EPA) estimates that there are over 40,000 sanitary sewer overflows each year — the majority caused by grease buildup. Maintaining these sewers is costly - more than \$25 billion per year — a situation exacerbated by attendant cleanup fines levied by the EPA and/or the Authority Having Jurisdiction.

The 2006 IPC specifies that grease interceptors and automatic grease removal devices shall conform to PDI G101, ASME A112.14.3 or ASME A112.14.4 and be installed in accordance with the manufacturers' instructions. ICC Evaluation Service, Inc., which operates under the umbrella of the International Code Council, certifies these devices to the aforementioned standards.

The purpose of grease interceptors is to reduce the amounts of fat, oil, and grease (FOG) in waste water to acceptable levels in conformance with the IPC. Eating establishments, hospitals, hotels, convention centers, sports arenas, prisons, etc., generate huge amounts of FOG each year which they allow to enter

the waste water system, the grease readily adhering to the inner surface of piping materials. This becomes a primary cause for clogs, backups, overflows, and equipment failure as the accrued layers harden into crust as tough as baked clay, leading to a need for the replacement of the affected pipes.

The recent changes in the IPC on grease interceptor installation requirements are a result of the need to address these issues.

The definition Flow Control (Vented) has been added to define the device that is used on hydromechanical grease interceptors, formerly called grease traps. This new definition now clarifies the flow control device referenced and explained in Section 1003.3.4.2. This section of the IPC specifies that grease interceptors shall be equipped with devices that control the rate of water flow so it doesn't exceed the rated flow of the interceptor. This device must be vented and terminate at least 6 inches above the flood rim level or be installed in accordance with the manufacturer's instructions.

General Drainage Requirements for a Food Establishment

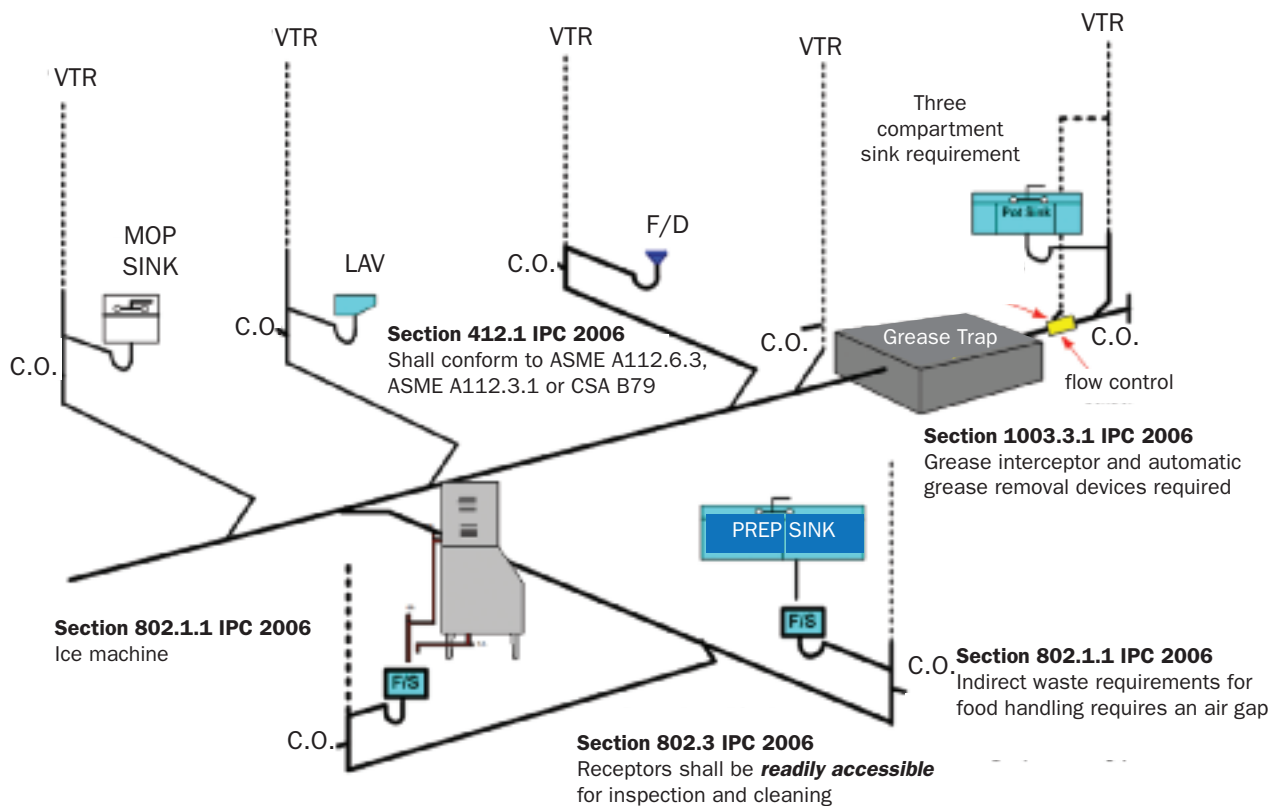

Also, a pair of additional flow rates and capacities has been added to Table 1003.3.4.1 in the IPC: “The modification to the table is in accordance with ASME A112.14.3 for standard flow rates and grease retention capacity ratings for grease interceptors.”

Grease retention capacity must be based on the flow-through rating of the grease interceptor and the discharge rate of the drainage pipe served. The waste flow capacity of a grease interceptor determines the quantity of grease that can be separated from the waste, which in turn, dictates the required capacity of the grease interceptor to hold the collected grease. The maintenance frequency for a grease interceptor is directly proportional to the retention capacity of the device.

Grease control devices must be cleaned or maintained regularly in order to function properly. Most agencies consider the requirement to install grease control devices to be the most important part of their fat, oil, and grease (FOG) control program. The general thinking is that even if kitchen Best Management Practices (BMP) is not fully implemented, the grease control device(s) will capture the grease and protect the sewer. However, some agencies are requiring mandatory monthly cleaning of conventional grease interceptors or daily cleaning or

maintenance of grease removal devices.

In closing, a combined effort from restaurant employees, code officials, sanitation districts, and industry working together will be what makes the difference. The City of Virginia Beach has undertaken a public outreach program in order to help eliminate fat, oil, and grease (FOG) from their sewers. A proposed ordinance is currently being reviewed by the city council. Virginia is also currently the home of several biodiesel refineries. Three produce biodiesel from soy and a few others produce biodiesel from waste grease and oils. ■

Lee Clifton is the Director of Plumbing Programs for the International Code Council, Plumbing, Mechanical & Fuel Gas (PMG). Prior to joining the Code Council, Lee was with the City of Los Angeles for 21 years. As the Principal Inspector with the City of Los Angeles this included planning, organizing and coordinating the training programs for approximately 200 inspectors and clerical staff that work for the Housing Department. Lee currently serves on the Board of Directors for the Southern California Health and Housing Council. And participating on the Strategic Planning Committee to end lead poisoning in Los Angeles County. In prior years Lee also served as a Senior Plumbing Training Officer for the Department of Building and Safety and has taught model plumbing code for the Plumbing, Heating, Cooling, Contractor Association of the Greater Los Angeles Area and the North Orange County Regional Occupation Program over the past 20 years.

Ready for a quality home?



New Shelter Construction, Inc.

3714 Mountain Road

Haymarket, VA 20169

703-754-7196

Contact Jeff Heflin, Owner

Custom Framed Homes • Log Homes • Additions

Full line of doors and windows, specializing in Andersen.



Reviewing HVAC Designs

by Wes Davis

Building officials routinely require heating, ventilation and air conditioning (HVAC) system design information as part of the permitting process for commercial buildings, but some hesitate to request the same information for residential HVAC systems. As a reminder, the 2006 International Residential Code (IRC) requires the following.

- Section 1401.3: “Heating and cooling equipment shall be sized based on building loads calculated in accordance with ACCA [Air Conditioning Contractors of America] Manual J or other approved heating and cooling calculation methodologies.”
- Section 1601.1: “Duct systems serving heating, cooling and ventilation equipment shall be fabricated in accordance with the provisions of this section and ACCA Manual D or other approved methods.

From my experience, building officials do not require HVAC design information because they think it would take too long to properly review the load calculation and duct design, they may be concerned that they do not know what to look for and would not know how to address a contractor’s challenges, or they may believe that air conditioning does not present a health or safety issue. The fact is that HVAC design or installation problems can affect a home’s structural integrity and affect occupants’ safety and health.

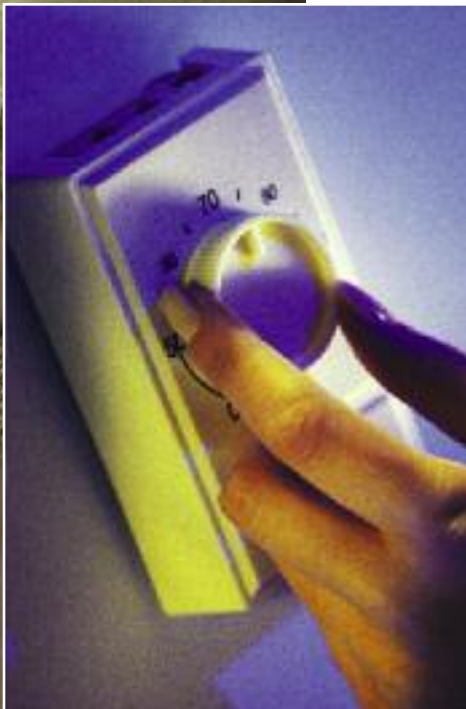

Comfort cooling has become standard equipment for most homes built today, and the building codes require that these systems be properly designed. Code officials are charged with enforcing this requirement and should therefore review the load calculation and duct design.

Load Calculation

If identical homes are built in Boston and Phoenix, the one in Boston will use more heating and the one in Phoenix will use more cooling. This may seem like an obvious consideration, but some HVAC system designers will use Phoenix’s summer temperature to determine the cooling needs for the Boston home and Boston’s winter temperature for the Phoenix home. They may seek to justify this by recalling a scorching Massachusetts summer and a long Arizona winter. However, rather than relying on isolated historic or anecdotal examples, building officials should make use of the high and low design temperature data that has been developed by scientific and engineering groups to 99 percent accuracy.¹

For example, ACCA Manual J, Table 1A, gives the summer design temperature for Ft. Meyers, Florida, as 93°F. There will be some scorching July afternoons when the temperature rises even higher, but from year to year this will only occur 1 percent of the time. Meanwhile, the winter design temperature for Ames, Iowa, is -6°F. There will be some bone-chilling January nights when

the mercury drops even further, but 99 percent of the year the weather will be warmer. Thanks to such highly accurate design temperature data it is easy to examine a load calculation and determine if the designer used an “extreme” temperature. To return to our example, a building official in Ft. Meyers should look for a summer design temperature of 93°F and a winter design temperature of 47°F (Figure 1), and his or her counterpart in Ames should look for a winter design temperature of 6°F and a summer design temperature of 90°F (Figure 2). Anything outside of these ranges does not comply with the recognized procedure of ACCA Manual J prescribed by the 2006 IRC.

Indoor heating and cooling design temperatures that will satisfy most occupants are also available from ACCA²: 70°F for winter heating and 75°F for summer cooling.³ Of course, the subjective indoor conditions provided for one homeowner may be too high or too low for another, but HVAC designers should carefully document the justification for choosing anything but these common design temperatures.

Basically, ACCA Manual J considers four factors: the temperature difference (indoor and outdoor), the ability of heat to pass through the various building components (walls, windows, doors, etc.), the area of the space conditioned and moisture. The difference between the inside and outside temperatures is one of the basic

Worksheet A Location and Design Conditions Cobb Residence			
State: Florida	City: Ft. Myers	Elevation = 15 Ft	Latitude = 26°
Indoor Conditions, Heating: DB 70 °F	RH =	Indoor Conditions, Cooling: DB 75 °F	RH = 50%
Table 1 Conditions	99% DB = 47 °F	1% DB = 93 °F	Grains Difference = 53 Daily Range = Medium
Design Temperature Differences	HTD = 70 - 47 = 23 °F		CTD = 93 - 75 = 18 °F

Figure 1. Ft. Meyers, Florida, ACCA residential design worksheet.

Worksheet A Location and Design Conditions			
State: Iowa	City: Ames	Elevation = 955 Ft	Latitude = 42 Degrees North
Indoor Conditions, Heating: DB 70 °F	RH = 20%	Indoor Conditions, Cooling: DB 75 °F	RH = 50%
Table 1 Conditions	99% DB = -6 °F	1% DB = 90 °F	Grains Difference = 38 Daily Range = Medium
Design Temperature Differences	HTD = 70 - (-6) = 76 °F		CTD = 90 - 75 = 15 °F

Figure 2. Ames, Iowa, ACCA residential design worksheet.



GSSN

MECHANICAL CONSULTING SERVICES

— RESIDENTIAL — COMMERCIAL — NEW CONSTRUCTION — BUILD-OUTS —

- ***Providing Heat Loss/Gain Calculations and System Design***
- ***Processing of County Permit Applications***
- ***Accurate Project Details, Installation & Inspection Checklists***
- ***On Site Walk Throughs***
- ***Complete Duct Design & Materials List Available***

For Fast, Reliable Service, Call

Office: 540-868-1146
Mobile: 540-664-2788

Serving All Northern Virginia — All Major Credit Cards Accepted

Reviewing HVAC Designs (continued)

considerations for proper load calculation. If the HVAC system designer began the process with the wrong design conditions, the resulting load calculation can be completely inaccurate. Other factors include design humidity, altitude and latitude.

Equipment Selection

The next step in HVAC design review is to look at equipment selection. Load calculations produce the values, in British thermal units per hour (Btu/h), for selecting the equipment. The best place to find these values is in the original equipment manufacturer (OEM) performance data. Most OEMs provide performance data that rate their equipment at different operating conditions. For example, a 2.5-ton air conditioner may be rated at a slightly higher capacity in Seattle, Washington, because of the mild climate but at a lower capacity in Phoenix, Arizona, because the unit cannot produce as much cool air when it is 108°F outside (the ACCA 1-percent design temperature). Figure 3 uses a fictitious air conditioner model to illustrate a performance swing of 15 percent or more based on the operating conditions.

Duct Design

The evaluation of duct design is very subjective because of the wide varieties of layouts, fittings, etc. However, one aspect is very easy to evaluate: return air duct paths. ACCA Manual D, Section 1-4, provides that “there must be a low-resistance return air path between every room and the air handler (or furnace).” IRC Section M1403.1 refers to the “minimum unobstructed total area of the outside and return air ducts” for heat pumps. In other words, larger rooms that usually have their doors closed, such as bedrooms and home offices, pose a need for air to get back to the air handler or furnace.

If a low-resistance return air path is not present, the air handler or furnace creates negative pressure inside the home. This negative pressure draws air from fireplaces, the vent pipes for some furnaces and gas clothes dryers, and other fuel-burning appliances that use natural draft venting to carry away carbon monoxide (CO). As a result, the CO is not properly exhausted—posing a potentially serious health and safety risk. Reviewing the duct layout for large return grills in common areas and small return grills in rooms with normally closed doors

XYZ Air Conditioners – Detailed Cooling Capacities Model AC-30 with Coil AC-030							
Evaporator Air		Condenser Entering Air Temp – DB (F)					
CFM	EWB (F)	85		95		105	
		Capacity		Capacity		Capacity	
		Total	Sensible	Total	Sensible	Total	Sensible
875	72	34,610	18,190	33,100	17,620	31,520	17,020
	67	31,400	22,240	30,000	21,650	28,520	21,040
	63	28,620	26,290	27,350	25,680	26,020	25,040
	57	27,840	27,840	26,800	25,740	25,740	25,740
1000	72	35,250	19,090	33,680	18,500	32,030	17,890
	67	31,990	23,660	30,530	23,060	29,000	22,440
	63	29,020	29,020	28,020	26,560	26,770	26,770
	57	29,020	29,020	27,930	26,560	26,770	26,770
1125	72	35,720	19,920	34,110	18,500	32,030	17,890
	67	32,430	25,010	30,930	23,060	29,000	22,440
	63	29,970	29,970	28,850	26,560	26,770	26,770
	57	30,000	30,000	28,850	28,850	27,640	27,640

Figure 3. Example air conditioner performance data.

— VPMIA Officers —

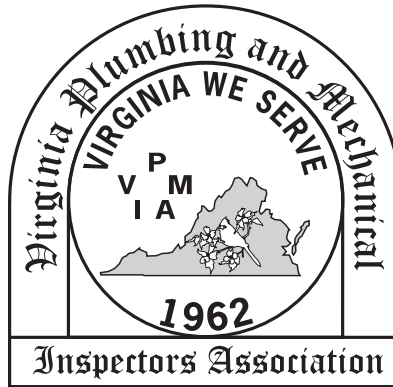

2007 VPMIA Board of Directors

<i>President</i>	Dennis Martinelli
<i>Vice President</i>	John W. Mills
<i>Secretary</i>	John Michael Clift
<i>Treasurer</i>	Wayne Kushner
<i>Executive Secretary</i>	Geary Showman

2007 Directors

Director at Large	John Seay
District 1	Ron Bladen
District 2	Gregory Stubanus
District 3	Bane F. Compton
District 4	John W. Mills
District 5	Louis Beck
District 6	Stanley J. Gregory, Jr.
District 7	John Micheal Cliff
District 8	David Harris

2007 Committee Chairmanships

Advertising/Yearbook	Ron Bladen
Audit	Geary Showman
Awards	John Seay
By-Laws / Parliamentarian	Charlie Gerber
Cert / Education / Training	Wayne Kushner
Finance	Geary Showman
Fuel Gas/Mechanical Code	Richard Grace
Legislative	Rick Witt
Mechanical Code	Richard Grace
Membership / Website	James Anjam
Nominating	John Seay
Plumbing Code	James Anjam
Residential Code	James Anjam
Resolutions	Paul Hostetler
School of Instruction	Wayne Kushner
Time and Place	Kathy Dye



At the 2007 Banquet, Dave Shapiro administered the oaths of office for incoming VPMIA President, Vice President, Treasurer and Secretary.

A

Adams, Paul M. (8)
Life Member
Post Office Box 1134
Grandy, NC 27939
252-453-6164
Netmit@aol.com

Addie, Sonia (1)
Plumbing Code Inspector
Arlington County
2100 Clarendon Blvd, Suite 800
Arlington, VA 22201
703-228-3866
703-228-7406 FAX
saddie@arlingtonva.us

Aldridge, William "Bill" (3)
Building Inspector
Town of Christiansburg
100 East Main Street
Christiansburg, VA 24073-3029
540-382-6120 Ext 186
540-381-7238 FAX
baldridge@christiansburg.org

Allen, Michael L. (6)
Code Enforcement Office
City of Emporia
P.O. Box 511
Emporia, VA 23847
434-634-6315
434-634-0003 FAX
mike.allen@ci.emporia.va.us

Altizer, Charles (6)
Virginia State Fire Marshall, DHCD
501 N. Second Street
Richmond, VA 23219
804-371-7154
804-371-7092 FAX
charles.altizer@dhcd.virginia.gov

Alves, Kenneth (8)
Building Codes Inspector
City of Newport News
2400 Washington Avenue
Newport News, VA 23607
757-926-8865
757-926-8311 FAX
kalves@nngov.com

Amiri, Shahriar (1)
Chief Building Official
Arlington County
2100 Clarendon Blvd, Suite 804
Arlington, VA 22201
703-228-3848
703-228-7046 FAX
samiri@arlingtonva.us

Anderson, Jeffrey H. (6)
Residential Combination Inspector
Chesterfield County
PO Box 40
Chesterfield, VA 23832
804-814-7005
804-778-7512 FAX
andersonj@chesterfield.gov

Anjam, James (1)
Manager, Inspection Section
Arlington County
2100 Clarendon Blvd, Suite 800
Arlington, VA 22201
703-228-3875
703-228-7048 FAX
janjam@arlingtonva.us

Antonowics, Ricky (1)
Master Combination Inspector
Fairfax County
12055 Government Center Pkwy
Fairfax, VA 22035
703-324-1711
703-324-3901 FAX
rantonowics@fairfaxcounty.gov

B

Baker, Johnnie (1)
Plumbing Plans Reviewer
Loudoun County
PO Box 7000 MSC 60B
Leesburg, VA 20177-7000
703-771-5756
703-737-8546 FAX
jbaker@loudoun.gov

Baldwin, Jr., Edward J. (2)
Life Member
City Of Harrisonburg
409 S. Main Street
Harrisonburg, VA 22801
540-432-7700
540-432-7777 FAX
judb@ci.harrisonburg.va.us

Ballard, Jr., William H. (1)
Cross Connection/Plumbing Inspector
Arlington County
2100 Clarendon Blvd, Suite 800
Arlington, VA 22201
703-228-3853
703-228-7046 FAX
W.Ballard@arlingtonva.us

Bartel, Tracy J. (6)
Plumbing & Mechanical Inspector
Henrico County
PO Box 27032
Richmond, VA 23273
804-501-4231
804-501-4984 FAX

Bartell, Richard (7)
Chief Building Official
Hanover County
PO Box 470
Hanover, VA 23069
804-537-6039
804-537-6247 FAX
rabartell@co.hanover.va.us

Beahm, David (2)
Building Official
Warren County
220 N. Commerce Avenue, #400
Front Royal, VA 22630
540-636-9973
540-636-4698 FAX
dbeahm@warrencountyva.net

Beavon, Jesse D. (5)
Facilities Construction & Maintenance
Manager
Spotsylvania County
PO Box 116
Spotsylvania, VA 22553
540-507-7702
540-582-6304 FAX
jbeavon@spotsylvania.va.us

Beck, JR., Louis, (5)
Combination Inspector
Goochland County
PO Box 119
Goochland, VA 23063
804-556-5815 Ext 6209
804-556-5651 FAX
lbeck@co.goochland.va.us

Becker, David (1)
Engineer
Fairfax County
12035 Government Ctr Pkwy, Suite 424
Fairfax, VA 22035
703-324-2849
David.becker@fairfaxcounty.gov

Berkley, Arthur E. (8)
Director of Inspections
Isle Of Wight County
PO Box 80
Isle Of Wight, VA 23314
757-365-6216
757-357-0771 FAX
aberkley@isleofwightus.net

Bladen, Ron (1)
Code Specialist II
Fairfax County
12055 Gov Center Pkwy, Suite 324
Fairfax, VA 22035
703-324-1651
703-324-1614 FAX
ronald.bladen@fairfaxcounty.gov

Boomer, Jr., Bernard (2)
Combination Inspector
City of Newport News
2400 Washington Avenue
Newport News, VA 23607
757-926-8773
757-926-8311 FAX

Active Membership Roster —

Borders, Stephen P. (5)
Life Member
Building Official
Greene County
PO Box 358
Stanardsville, VA 22973
434-985-5204
434-985-1459 FAX
sborder@gcva.us

Boylan, Daniel (1)
Mechanical Inspector
Loudoun County
PO Box 7000 MSC 60B
Leesburg, VA 20177-7000
703-771-5031
703-737-8546 FAX

Branner, Tommy (2)
Building Codes Inspector
City of Harrisonburg
409 South Main Street
Harrisonburg, VA 22802
540-432-7700
tommyb@ci.harrisonburg.va.us

Brooking, Michael (5)
Building Inspector
Goochland County
PO Box 119
Goochland, VA 23063
804-556-5651
mbrooking@co.goochland.va.us

Brown, Mike (1)
Master Inspector
Fairfax County
12055 Government Center Pkwy
Fairfax, VA 22035
703-324-1679
703-324-1846 FAX
Michael.Brown2@fairfaxcounty.gov

Brunkow, Paul (7)
Building Official
Westmoreland County
PO Box 100
Montross, VA 22520
804-493-0120
804-496-0604 FAX
buildings@westmoreland-county.org

Bryan, Jerry (6)
Mechanical Inspector
City of Richmond
900 E. Broad Street, #110
Richmond, VA 23219
804-646-6983
804-646-6948 FAX
bryanjw@ci.richmond.va

Bryant, Clyde (8)
Senior Code Specialist
City of Norfolk
400 Granby Street
Norfolk, VA 23510-1914
757-664-6536
757-664-6841 FAX
clyde.bryant@norfolk.gov

Bryant, Sam (8)
Senior Code Specialist
City of Norfolk
400 Granby St.
Norfolk, VA 23510-1914
757-664-6551
757-664-6841 FAX
Sammy.bryant@norfolk.gov

C

Caleb, Sulzen (5)
Building Inspector
Louisa County
PO Box 160
Louisa, VA 23093
540-967-3430
540-967-3486 FAX
csulzen@louisa.org

Campbell, Curtis W. (6)
Combination Building Inspector
Chesterfield County
PO Box 40
Chesterfield, VA 23832
804-814-7003
804-778-7512 FAX
campbellcw@chesterfield.gov

Catan-Rose, Paula (1)
Mechanical/Elevator Inspector
Loudoun County
PO Box 7000 MSC 60B
Leesburg, VA 20177-7000
703-737-8744
703-737-8546 FAX

Christian, Carl (8)
Plumbing Inspector Supervisor
City of Virginia Beach
2405 Courthouse Drive
Virginia Beach, VA 23456
757-427-4211
757-426-5777 FAX

Clayborn, Steven (1)
Supervising Combination Inspector
Fairfax County
12055 Government Center Pkwy,
Suite 634
Fairfax, VA 22035
703-324-1971
703-324-1846 FAX
sjc36chevy@aol.com

Clements, Darin (5)
Plumbing/Mechanical Inspector
City of Charlottesville
PO Box 911
Charlottesville, VA 22902
434-970-3317
434-970-3359 FAX
clementd@charlottesville.org

Clift, John Michael (7)
Building Official
King George County
10459 Courthouse Rd #104
King George, VA 22485
540-775-8557
540-775-3139 FAX
mclift@co.kinggeorge.state.va.us

Cole, Frank R. (1)
Engineer III
Fairfax County
12055 Government Center Pkwy,
Suite 316
Fairfax, VA 22035
703-324-1688
703-324-1614 FAX
frank.cole@fairfaxcounty.gov

Compton, Bane F. (3)
Combination Inspector
City of Roanoke
215 Church Avenue, Room 170
Roanoke, VA 24011
540-853-1139
540-853-1594 FAX
bane.compton@roanokeva.gov

Cooper, John G. (6)
Plumbing Plans Reviewer
Henrico County
PO Box 27032
Richmond, VA 23273
804-501-4371
804-501-4984 FAX
coo07@co.henrico.va.us

Cooper, John L. (1)
Combination Inspector
Fairfax County
211. West Main St
Purcellville, VA 20133
703-989-3173
540-338-2442 FAX

Cooper, Kevin (5)
Government Inspector
Alutiiq International, LLC.
2055 Boulders Road
Charlottesville, VA 22911
434-951-4737

Cousins, Paul (8)
Mechanical Plan Examiner
City of Hampton
22 Lincoln Street
Hampton, VA 23669
757-727-6676
757-727-6557 FAX
pcousins@hampton.gov

Craddock, Ron (5)
Government Inspector
Alutiiq International, LLC.
2055 Boulders Road
Charlottesville, VA 22911
434-951-4737
ron.craddock@us.army.mil

Cubbage, Gary Lee (1)
Mechanical Inspector
Loudoun County
PO Box 7000
1 Harrison Street, S.E.
Leesburg, VA 20177-7000
703-771-5684
703-737-8546 FAX
Gary.Cubbage@loudoun.gov

— Active Roster Continued —

D

Davis, Stephen (2)
Deputy Building Official
Rockingham County
PO Box 1252
Harrisonburg, VA 22803
540-564-3057
540-564-2922 FAX

Decatur, Thomas (1)
Plumbing Plans Reviewer
Arlington County
2100 Clarendon Blvd, Suite 804
Arlington, VA 22201
703-228-3856
703-228-7046 FAX

Deel, Gary (4)
Building Official
Dickerson County
PO Box 773
Clintwood, VA 24228
276-926-1673
276-926-6227 FAX
gary.deel@bid.dcwin.org

DeHaven, Larry H. (2)
Life Member
107 North Kent Street
Winchester, VA 22601
540-665-5656
540-678-0682 FAX

Dellenger, Michael (2)
Plan Review/Building Codes
City Of Harrisonburg
409 S. Main Street
Harrisonburg, VA 22801
540-432-7700
540-432-7777 FAX
miked@ci.harrisonburg.va.us

DeMaury, Andrew (3)
Building Official
Montgomery County
PO Box 2506
Christiansburg, VA 24068
540-382-5750
540-381-6880 FAX

Derrer, Terry (2)
Combination Inspector
Rockingham County
PO Box 1252
Harrisonburg, VA 22803
540-564-3040
540-564-2922 FAX

DeShazo, Hassell (3)
Life Member
6783 Mitchell Rd
Ridgeway, VA 24148
276-956-2499

Dolan, Michael (3)
Building Official
City of Covington
333 W. Locust Street
Covington, VA 24426
540-965-6356
540-965-6307 FAX
mdolan@covington.va.us

Duckworth, William N. (8)
Combination Inspector
City of Portsmouth
801 Crawford Street
Portsmouth, VA 23704
757-393-8531
757-393-5108 FAX
duckworthw@portsmouthva.us

Duffy, Dave (5)
Building Official
Goochland County
PO Box 119
Goochland, VA 23063
804-556-5351
804-556-5651 FAX
dduffy@co.goochland.va.us

Dupler, William (6)
Building Official
Chesterfield County
PO Box 40
Chesterfield, VA 23832
804-748-1611
804-751-4713 FAX
duplerd@co.chesterfield.va.us

Duvall, William J. (7)
Plumbing/Mechanical Inspector
Hanover County
PO Box 470
Hanover, VA 23069
804-365-6138
804-365-6465 FAX
wjduvall@co.hanover.va.us

Dye, Kathleen T. (1)
Life Member
Retired
8728 Sugarwood Lane
Manassas, VA 20110-3847
703-368-5714

Dyer, Lorenzo (6)
State Building Code
Senior Engineer, DHCD
501 N. Second Street
Richmond, VA 23219
804-371-7160
804-371-7092 FAX
lorenzo.dyer@dhcd.virginia.gov

E

Elder, Gregory (7)
Building Inspector
King George County
10459 Courthouse Road, #104
King George, VA 22485
540-775-3061
540-775-3139 FAX
gelder@co.kinggeorge.state.va.us

Ely II, George (6)
Mechanical Inspector
City of Richmond
900 East Broad Street, #110
Richmond, VA 23219
804-646-6984
804-646-6948 FAX

English, Jimmy (3)
Building & Code Official
City Of Bedford
PO Box Drawer 807
Bedford, VA 24523
540-587-6021
540-875-7533 FAX
jenglish@ci.bedford.va.us

Eppard, Bonne L. (5)
Building Inspector
Greene County
PO Box 358
Stanardsville, VA 22973
434-985-5204
434-985-1459 FAX
beppard@gcva.gov

Estep, Brian
Building Inspector
Prince George County
PO Box 68
Prince George, VA 23875
804-722-8643
804-722-0702 FAX
bestep@princegeorgeva.org

F

Farrow, Ray (8)
Mechanical Inspector
City of Norfolk
400 Granby St.
Norfolk, VA 23510-1914
757-664-6559
757-664-6897 FAX
raymond.farrow@norfolk.gov

Fauber, David (8)
Building Inspector
Town of Cape Charles
2 Plum Street
Cape Charles, VA 23310
757-331-2176
757-331-4820 FAX

Fields, Thomas (1)
Plumbing Inspector
Loudoun County
PO Box 7000 MSC 60B
Leesburg, VA 20177-7000
703-771-5759
703-737-8546 FAX
trfjr2@shentel.net

Fix, Fred (3)
Building Official
City of Buena Vista
2039 Sycamore Ave
Buena Vista, VA 24416
540-261-8635
540-261-2142 FAX
inspector@buenavistava.com

Fletcher, Walter (2)
Plumbing/Mechanical/Gas Inspector
City of Winchester
15 N. Cameron Street, #410
Winchester, VA 22601
540-667-1815
540-722-3618 FAX
fletcherwr@ci.winchester.va.us

Forrest, David (8)
Combination Inspector
City of Newport
2400 Washington Avenue
Newport News, VA 23607
757-926-8864
757-926-8311 FAX
dforrest@nngov.com

Fortner, Richard S. (8)
Senior Codes Specialist/Mechanical
City of Norfolk
400 Granby Street
Norfolk, VA 23510-1914
757-664-6547
757-664-6897 FAX
richard.fortner@norfolk.gov

Foster, Rodney
Building Official
Town of Colonial Beach
18 N. Irving Avenue
Colonial Beach, VA 22443
804-224-7214
804-224-7185 FAX
cbbuild@3n.net

Frazier, Edwarren (5)
Building Inspector
Madison County
PO Box 1206
Madison, VA 22727
540-948-6102
540-948-3843 FAX
cmycuts1@yahoo.com

Frivetti, Don (6)
Inspector
City of Richmond
900 East Broad Street, #110
Richmond, VA 23219
804-646-6981
804-646-6948 FAX

Fulcher, Jr., Chas.W. (3)
Inspections Division Supervisor
City of Danville
PO Box 3300
Danville, VA 24541
434-799-5263 Ext 232
434-797-8919 FAX
fulchew@ci.danville.va.us

G

Gerber, Charles E. (6)
Plumbing/Mechanical Supervisor
County of Henrico
PO Box 27032
Bldg. Insp. Department
Richmond, VA 23273
804-501-4369
804-501-4984 FAX
ger02@co.henrico.va.us

Gilbert, William (5)
Commercial Inspections Chief
Albemarle County
401 McIntire Rd, #211
Charlottesville, VA 22902
434-296-5831
434-972-4126 FAX
w.gilbert@albemarlecounty.org



Laurie/Daniel Crigler
(540) 948-6230 Fax (540) 948-5617

Plumbing • Hydronic Heating
Consulting • Project Management
Class "A" License #069344

P.O. Box 418
Aroda, Virginia 22709

Gill, Bernie (1)
Construction Codes IV
Arlington County
2100 Clarendon Blvd, Suite 804
Arlington, VA 22201
703-228-3873
703-228-7046 FAX
bgill@arlingtonva.us

Gillispie, Gary L. (1)
Plumbing Inspector
Loudoun County
PO Box 7000 MSC 60B
Leesburg, VA 20177-7000
703-737-8298

Glascocock, Earnest (1)
Combination Inspector
Prince William County
5 County Complex Court
Prince William, VA 22192
703-792-7102
703-580-1578 FAX
eglascock@pwcgov.org

Grabowski, Francis A. (8)
Code Inspector
City of Virginia Beach
2505 Courthouse Drive
Virginia Beach, VA 23456
757-385-8066
757-385-5777 FAX

Grace, Richard E. (1)
Engineer III, Plan Review Division
Fairfax County
12055 Government Center Pkwy,
Suite 316
Fairfax, VA 22035
703-324-1687
703-314-1614 FAX
richard.grace@fairfaxcounty.gov

Gray, Dale (1)
Inspections
Loudoun County
PO Box 7000 MSC 60B
Leesburg, VA 20177-7000
703-777-0555
703-737-8546 FAX

Gray, Daniel (8)
Combination Inspector
City of Portsmouth
801 Crawford Street
Portsmouth, VA 23704
757-393-8531
757-393-5108 FAX
grayd@portsmouth.gov

Gregory, Jr., Stanley "Joe" (6)
Building Inspector III
Chesterfield County
P.O. Box 40
Chesterfield, VA 23832
804-814-6979
804-778-7512 FAX
gregorys@chesterfield.gov

Grimmell, Mark (1)
Plumbing & Gas Field Supervisor
Loudoun County
PO Box 7000
1 Harrison Street, S.E.
Leesburg, VA 20177-7000
703-771-5765
703-737-8546 FAX
Mark.Grimmell@loudoun.gov

Grivetti, Don (1)
Plumbing Inspector
City of Richmond
900 East Broad Street, #110
Richmond, VA 23219
804-646-6636
grivettidc@ci.richmond.va.us

H

Haga, Jamie (4)
Building Inspector
Grayson County
PO Box 217
Independence, VA 24348
276-773-2322
276-773-3673 FAX
gobi2@adelphia.net

Haines, Cheri (8)
Building Code Administrator
City of Virginia Beach
2405 Courthouse Drive
Virginia Beach, VA 23456
757-385-4211
757-385-5777 FAX

Hale, Jr., Robert (1)
Building Official
Town of Warrenton
18 Court Street
Warrenton, VA 20188
540-347-2405
540-347-2414 FAX
rhale@warrentonva.gov



PLUMBING and HEATING

Service • Remodeling • New Construction • Septic Systems
Excavating • Electrical Repairs & Service Upgrades
Well Pump Repair, Replacement & New Installation

“OUR SERVICE IS OUR SALE”

www.eandeplumbing.com

(540) 337-1856 • (540) 943-7727 • (540) 337-9453

296 Draft Avenue Stuarts Draft, VA 24477

VA Contractors Lic. #2705 040015A

Hardee, Cecil F. Jr. (1)
Section Supervisor
Fairfax County Park Authority
12055 Government Center Pkwy
Fairfax, VA 22035
703-324-8434
703-324-3987 FAX
cecil.hardee@fairfaxcounty.gov

Harper, Skip (5)
Building Inspector
Louisa County
PO Box 160
Louisa, VA 23093
540-967-3430
540-967-3486 FAX
sharper@louisa.org

Harris, David R. (8)
Senior Building Codes Inspector
City of Newport News
2400 Washington Avenue
Newport News, VA 23607
757-926-8866
757-926-8311 FAX
dharris@nngov.com

Harsh, Anthony (1)
Plumbing & Gas Inspector
Loudoun County
1 Harrison Street, S.E.
Leesburg, VA 20177-7000
703-777-0575
703-737-8546 FAX
Andy.Harsh@loudoun.gov

Haskett, James (8)
Senior Code Specialist
City of Norfolk
400 Granby St.
Norfolk, VA 23510-1914
757-664-6553
757-664-6897 FAX
jim.hasket@norfolk.gov

Hatcher, Sr., Ricky Lee (8)
Plumbing/Mechanical Inspector
City of Hampton
22 Lincoln Street
Hampton, VA 23669
757-727-6287
757-727-6557 FAX
rhatcher@hampton.gov

Heddings, Joseph (3)
Building Official
Campbell County
PO Box 100
Rustburg, VA 24588
434-332-9608
434-332-9693 FAX
jlheddings@co.campbell.va.us

Herron, Rick (7)
Building Inspector
King George County
10459 Courthouse Road, #104
King George, VA 22485
540-775-7111
540-775-3139 FAX
rherron@co.kinggeorge.state.va.us

Hewitt, William (8)
Combination Inspector
City of Portsmouth
801 Crawford Street
Portsmouth, VA 23704
757-393-8531
757-393-5108 FAX
hewitt@portsmouthva.gov

Hines, William F. (1)
Life Member
4086 Stanberry Avenue
Marshall, VA 20115
540-364-2934
william.hines@fauquier.county.gov

Hodges, Jeffrey (7)
Building & Zoning Official
Essex County Tappahannock
PO Box 549
Tappahannock, VA 22450
804-443-4951
804-443-4157 FAX
jeffhodges@hotmail.com

Hostetler, Paul D. (5)
Life Member
Retired
518 Pebble Hill Court
Charlottesville, VA 22901
434-964-1183
paulhostetler@peoplepc.com

Hudson, Brad (7)
Building Technical Assistant
King George County
10459 Courthouse Road, #104
King George, VA 22485
540-775-8554
540-775-3139 FAX
bhudson@co.kinggeorge.state.va.us

Hudson, Charles (6)
Building/Code Official
Town of South Hill
211 South Mecklenburg Avenue
South Hill, VA 23970
434-447-5041
434-447-5064 FAX
chudson@southhillva.org

Humrich, Rex R. (8)
Plumbing Inspector
City of Virginia Beach
2405 Courthouse Drive
Virginia Beach, VA 23456
757-385-8066

Hunter, Robert Joseph (8)
Cross Connection Specialist
City of Norfolk
400 Granby Street
City of Norfolk, VA 23510
757-664-6832
757-664-6841 FAX
robert.hunter@norfolk.gov

Hurt, Jesse R. (5)
Life Member
18060 James Madison Highway
Gordonsville, VA 22942
540-832-3767

Hutto, J. Ralph (6)
Plumbing Inspector
City of Richmond
900 East Broad Street, #110
Richmond, VA 23224
804-737-3907
804-646-6948 FAX

— Active Roster Continued —

J

Johnson, Michael (8)
Mechanical Inspector
City of Newport News
2400 Washington Avenue
Newport News, VA 23607
757-926-8860
757-926-8311 FAX
mrjohnson@nngov.com

Jones, Frank D. (8)
Mechanical Inspector
City of Virginia Beach
2405 Courthouse Drive
Virginia Beach, VA 23456
757-427-8065
757-426-5777 FAX

K

Kesner, Marty (1)
Plumbing Inspector
Loudoun County
PO Box 7000 MSC 60B
Leesburg, VA 20177-7000
703-737-8297

Kidd, David (3)
Building Code Engineer
Virginia Tech
1240 Smith Creek Road
Christiansburg, VA 24073
540-231-9578
540-231-5590 FAX
dmkidd@vt.edu

Kipps, Kenneth (1)
Plumbing Inspector
Loudoun County
PO Box 7000 MSC 60B
Leesburg, VA 20177-7000
703-737-8019
703-737-8546 FAX

Koll, Paul (7)
Building Official
Gloucester County
PO Box 604
Gloucester, VA 23061
804-693-2744
804-693-4664 FAX
pkoll@gloucesterva.info

Kurtz, Dennis (5)
Plan Review
Culpeper County
302 N. Main Street
Culpeper, VA 22701
540-727-3405
540-727-3461 FAX
dkurtz@culpepercounty.gov

Kushner, Wayne (1)
Commercial Combination Inspector
Fairfax County
12055 Government Center Pkwy
Fairfax, VA 22035
703-324-1755
703-324-1846 FAX
wayne.kushner@fairfaxcounty.gov

L

Lam, Boyd W. (2)
Building Official
Rockingham County
20 E. Gay Street
Harrisonburg, VA 22802
540-564-3030
540-564-2922 FAX

Laney, Ricky F. (5)
Residential Inspector
Spotsylvania County
PO Box 220
Spotsylvania, VA 22553
540-507-7242
540-507-7281 FAX
rlaney@spotsylvania.va.us

Laprade, Mike (3)
Plumbing/Cross Connection
Danville
PO Box 330
Danville, VA 24540
434-799-5263
434-797-8919 FAX
laprajm@ci.danville.va.us

Latuche, Sr., Randall (7)
Plumbing Inspections
City of Richmond
900 East Broad Street, #110
Richmond, VA 23219
804-646-3988
804-646-6948 FAX
latuchera@ci.richmond.va.us

Lawrence, Jr., Billy J. (8)
Mechanical Inspector
City of Newport News
2400 Washington Avenue
Newport News, VA 23607
757-926-8106
757-926-8311 FAX
blawrence@nngov.com

Leatherby, Eric (6)
Safety Engineer, DHCD
501 N. Second Street
Richmond, VA 23219
804-371-7165
804-371-7092 FAX
eric.leatherby@dhcd.virginia.gov

Lee, Jason (1)
Construction Code Inspector
Arlington County
2100 Clarendon Blvd, Suite 804
Arlington, VA 22201
703-228-3850
703-228-7046 FAX
jlee3@arlingtonva.us

Lester, Darius (5)
Building Official
Fluvanna County
PO Box 540
Palmyra, VA 22963
434-591-1935
434-591-1911 FAX
dlester@co.fluvanna.va.us

Lester, Ernest L. "Bud" (1)
Life Member
Retired
612 West Holly Avenue
Sterling, VA 20164
703-430-7898

Lewis, Michael G. (1)
Construction Code Supervisor
Arlington County
2100 Clarendon Blvd, Suite 804
Arlington, VA 22201
703-228-3868
703-228-7046 FAX

Liggan, Joseph R.
Life Member (Retired)
PO Box 652
Mechanicsville, VA 23111
804-769-2755

Lilly, Wayne (6)
Senior Building Code Inspector
City of Harrisonburg
PO Box 20031
Harrisonburg, VA 22801
540-432-7700
540-432-7777 FAX
wayne@ci.harrisonburg.va.us

Lindstrom, Paul (8)
Mechanical Inspector
City of Newport News
2400 Washington Avenue
Newport News, VA 23607
757-926-6925
757-926-8311 FAX
plindstrom@nngov.com

Lipscomb, J. Lee (6)
Plumbing/HVAC Inspect. Supervisor
Chesterfield County
PO Box 40
Chesterfield, VA 23832
804-748-1309
804-778-7512 FAX
LipscombL@chesterfield.gov

Littlefield, Casey (5)
Building Inspector
Louisa County
1 Woolfolk Avenue
Louisa, VA 23093
540-967-3430
540-967-3486 FAX
clittlefield@louisa.org

Lockhart, Bobby (1)
Plumbing Inspector/Plan Review
Loudoun County
PO Box 7000 MSC 60B
Leesburg, VA 20177-7000
703-771-5065
703-737-8546 FAX

— Active Roster Continued —

Lockhart, Scott (1)
Plumbing Inspector
Loudoun County
PO Box 7000 MSC 60B
Leesburg, VA 20177-7000
703-771-5768
703-737-8546 FAX

Lockhart, William (1)
Plumbing Inspector
Loudoun County
PO Box 7000 MSC 60B
Leesburg, VA 20177-7000
703-771-5768
703-737-8546 FAX

Lucas, James (7)
Plumbing Inspector
City of Richmond
900 East Broad Street, #110
Richmond, VA 23219
804-646-680
804-646-6948 FAX
lucasjn@ci.richmond.va.us

Lucy, Herb (7)
Plumbing/Mechanical Inspector
Hanover County
PO Box 470
Hanover, VA 23069
804-730-6062

Lynch, Paul (1)
Director, Residential Inspections
Division
Fairfax County
12055 Government Center Pkwy
Fairfax, VA 22035
703-324-1972
703-324-3901 FAX
plynch@fairfaxcounty.gov

M

Makely, James A. (1)
Combination Inspector
Fairfax County
12055 Government Center Pkwy,
Suite 634
Fairfax, VA 22035
703-324-1707
703-324-3901 FAX
james.makeley@fairfaxcounty.gov

Marcum, George (1)
Combination Inspector
Prince William County
5 County Complex Court
Prince William, VA 22192
703-792-4608
703-580-1578 FAX
gmarcum@pwcgov.org

Marsh, JR., Robert E. (1)
Plumbing Inspector
Loudoun County
PO Box 7000 MSC 60B
Leesburg, VA 20177-7000
703-771-5956
703-771-8546 FAX

Martin, Christopher (1)
Plumbing Inspector
Arlington County
2100 Clarendon Boulevard
Arlington, VA 22201
703-228-3854
703-228-7046 FAX
cmmartin@arlingtonva.us

Martinelli, Dennis (1)
Supervising Combination Inspector
Fairfax County
12055 Government Center Pkwy
Fairfax, VA 22035
703-324-1637
703-324-1846 FAX
dennis.martinelli@fairfaxcounty.gov

Massie, Stan (4)
Building Official
Town of Wytheville
P.O. Box 533
Wytheville, VA 24382
276-223-3339
276-223-3315 FAX
stanm@wytheville.org

Matkins, Janet (5)
Building Inspector
Louisa County
PO Box 160
Louisa, VA 23093
540-967-3430
540-967-3486 FAX
jmatkins@louisa.org

Mayhew, Darrell (7)
Plumbing-Mechanical Inspector
Hanover County
PO Box 470
Hanover, VA 23069
804-798-5842

McErlean, Edwin "Chip" A. (8)
Chief Inspector
City of Hampton
Codes Compliance Office
22 Lincoln Street
Hampton, VA 23669
757-727-6268
757-727-6557 FAX
cmcerlean@hampton.gov

McFarland, Jr., Roy N. (3)
Life Member
Cross Connection/Program Coordinator
Roanoke County
215 Church Avenue, Room 170
Roanoke, VA 24011-1592
540-853-1132
540-853-1594 FAX
roy.mcfarland@co.roanokeva.us

McIver, Curtis (6)
Associate Director, DHCD
501 N. Second Street
Richmond, VA 23219
804-371-7161
804-371-7092 FAX
curtis.mciver@dhcd.virginia.gov

McLehaney, Dustin (6)
Inspector
Chesterfield County
PO Box 40
Chesterfield, VA 23832
804-317-6420
804-778-7512 FAX
mclehaneyd@chesterfield.gov

McMahan, Alan (6)
Building Code Supervisor, DHCD
501 N. Second Street
Richmond, VA 23219
804-371-1157
804-371-7092 FAX
alan.mcmahan@dhcd.virginia.gov

McMahan, Anthony (8)
Plumbing/Mechanical Inspector
Gloucester County
PO Box 604
Gloucester, VA 23061
804-693-2744
804-693-7037 FAX
amcmahan@gloucestervera.info

McNaughton, Dennis (1)
Engineer III
Fairfax County
12055 Government Center Pkwy,
Suite 316
Fairfax, VA 22035
703-324-1643
703-324-1614 FAX
dennis.mcnaughton@fairfaxcounty.gov

McWhirt, Scott (5)
Combination Residential Inspector
Spotsylvania County
PO Box 220
Spotsylvania, VA 22553
540-507-7245
540-507-7281 FAX
smcwhirt@spotsylvania.va.us

Meadows, Chris (1)
Plumbing Inspector
Loudoun County
PO Box 7000 MSC 60B
Leesburg, VA 20177-7000
703-737-8547
703-737-8546 FAX

Mentzer, Delbert (1)
Mechanical Inspector
Loudoun County
PO Box 7000 MSC 60B
Leesburg, VA 20177-7000
703-737-8736
703-737-8546 FAX

Milbourne, Jerry (1)
Mechanical Inspector
Loudoun County
PO Box 7000 MSC 60B
Leesburg, VA 20177-7000
703-737-8718
703-771-8546 FAX

Milbourne, Michael (1)
Mechanical Inspector
Loudoun County
PO Box 7000 MSC 60B
Leesburg, VA 20177-7000
703-737-8742
703-737-8546 FAX

— Active Roster Continued —

Mills, John W. (3)
Building Official
Giles County
315 North Main Street
Pearisburg, VA 24134
540-921-2527
540-921-1846 FAX
hsnidow@gilescounty.org

Mimms, Donald (6)
Plumbing/Mechanical Inspector
Chesterfield County
PO Box 40
Chesterfield, VA 23832
804-814-6999
804-778-7512 FAX
mimmsd@co.chesterfield.va.us

Moore, James (1)
Supervising Combination Inspector
Fairfax County
12055 Government Center Pkwy
Fairfax, VA 22035
703-324-1704
703-324-1846 FAX
james.moore@fairfaxcounty.gov

More, Allen (8)
Mechanical Inspector
City of Virginia Beach
2405 Courthouse Drive
Virginia Beach, VA 23456
757-427-8065
757-426-5777 FAX

Morgan, Michael (8)
Senior Code Specialist
City of Norfolk
400 Granby Street
Norfolk, VA 23510-1914
757-664-6733
757-664-6841 FAX
michael.morgan@norfolk.gov

Moss, James (5)
Building Official
Grayson County
PO Box 217
Independence, VA 24348
276-773-2322
276-773-3673 FAX
bring@valink.com

Motely, Ralph (8)
Plumbing/Mechanical Inspector
York County
103 Service Drive
Yorktown, VA 23692
757-890-3522
757-890-3549 FAX
ralph.motley@yorkcounty.gov

Murphy, Patrick (6)
Chief Electrical/Plumbing Inspector
Code Administrator
City of Richmond
900 East Broad Street, #110
Richmond, VA 23219-6505
804-646-6962
804-646-6948 FAX
murphypj@ci.richmond.va.us

Murrell, Bernie (6)
Building Official
City of Colonial Heights
201 James Avenue
Colonial Heights, VA 23832
804-520-9298
804-524-8755 FAX
murellb@colonial-heights.com

Myers, Kenneth D. (1)
Senior Building Inspector
Stafford County
1300 Court House Rd.
Stafford, VA 22555
540-658-4661
540-727-3461 FAX
KMyers@co.stafford.va.us

N

Negley, Valrae (5)
Building/Fire Official
Spotsylvania County
PO Box 220
Spotsylvania, VA 22553
540-507-7232

Nelson, Richard (2)
Building Official
City of Winchester
15 N. Cameron Street, #410
Winchester, VA 22601
540-667-1815
540-722-3618 FAX
nelson@ci.winchester.va.us

Over 50 Years of Trusted Service

 **LEONARD-SPLAINE** Heating & Cooling

Quality Equipment ~ Expert Installation ~ Prompt Service

FEATURING

-  **TRANE**
-  **HEP**

Quiet, Durable and Energy Efficient with Aerodynamic Air Flow

- Residential and Commercial Service
- Accredited Technicians
- Radio Dispatched Trucks
- Prompt Fuel Oil Deliveries
- Emergency Service
- Worry-Free Service Plans
- Duct Work
- Service on All Makes

STATE LICENSED • BONDED - INSURED

Call Us For Your Heating Oil Needs ... Prompt Delivery. Affordable Rates

703-494-2855

Call Us for Fast, Friendly Service & a Free Estimate
www.leonardsplaine.com

Serving The Communities Of Burke, Clifton, Fairfax Station, Lorton And Southern Springfield



— Active Roster Continued —

Newsome, Warren (7)
Plumbing/Mechanical Inspector
Hanover County
PO Box 470
Hanover, VA 23069
804-730-6040
804-537-6465 FAX

Nicely, Brandon (3)
Building Official
Botetourt County
1 West Main Street, Box 2
Fincastle, VA 24090
540-473-8248
540-473-8304 FAX
bnicely@pgroup.net

Nick, Daniel (1)
Mechanical Inspector
Loudoun County
PO Box 7000 MSC 60B
Leesburg, VA 20177-7000
703-737-8985
703-737-8546 FAX

Nickell, Michael (2)
Building Official
County of Augusta
PO Box 590
Verona, VA 24482-0590
540-245-5717
540-245-5721 FAX
bi@co.augusta.va.us

O

Olszewski, Thomas (6)
Combination Residential
Building Inspector
Chesterfield County
9800 Government Center Parkway
Chesterfield, VA 23838
804-381-8682
804-778-7512 FAX
olszewskit@chesterfield.gov

Orr, Bob (5)
Senior Building Inspector
Culpeper County
302 N. Main Street
Culpeper, VA 22701
540-727-3405
540-727-3461 FAX
borr@culpepercounty.gov

Orrison, John (1)
Building Official
Town of Herndon
PO Box 427
Herndon, VA 20170
703-435-6850
703-318-8492 FAX
john.orrison@town.herndon.va.us

Owens, Ricky (6)
Plumbing Inspector
City of Richmond
900 East Broad Street, #110
Richmond, VA 23219
804-646-6979
804-646-6948 FAX
owensra@ci.richmond.va.us

P

Payne, Donald Lee (1)
Plumbing Inspector
Loudoun County
PO Box 7000 MSC 60B
Leesburg, VA 20177-7000
703-737-8855
703-737-8546 AX

Pearce, Randy (6)
Building Official
City of Emporia
PO Box 511
Emporia, VA 23847
434-634-6315
434-634-0003 FAX
rpearce@ci.emporia.va.us

Perrella, Gary (1)
Plumbing Inspector
Loudoun County
PO Box 7000 MSC 60B
Leesburg, VA 20177-7000
703-737-8299
703-737-8546 FAX

Perry, Kevin W. (5)
Residential Inspector
Spotsylvania County
10304 Spotsylvania Ave, Suite 400
Fredricksburg, VA 22408
540-507-7244
540-710-7119 FAX
KPerry@spotsylvania.va.us

Phelps, Richard (3)
Mechanical Inspector
City of Danville
PO Box 3300
Danville, VA 24540
434-799-5263
434-799-8919 FAX
phelpsr@ci.danville.va.us

Phipps, Leonard (8)
Mechanical Inspector
City of Chesapeake
PO Box 15225
Chesapeake, VA 23322
757-382-6018
757-382-8448 FAX

Poston, Paul (2)
Building Inspector II
Frederick County
107 N. Kent Street
Winchester, VA 22601
540-665-5656

Proctor, Jack (6)
Honorary Member, DHCD
501 N. Second Street
Richmond, VA 23219
804-371-7184
804-371-7092 FAX

Puffinberger, Jr., E. F. "Mike" (2)
Inspector
Frederick County
107 North Kent Street
Winchester, VA 22601
540-665-5656
540-678-0682 FAX

Pylant, Ray (1)
Building Official
Fairfax County
12055 Government Center Pkwy
Fairfax, VA 22035
703-324-1910
703-324-1846 FAX
ray.pylant@fairfaxcounty.gov

R

Redifer, Michael D. (8)
Life Member
Building Official
City of Newport News
2400 Washington Avenue
Newport News, VA 23607
757-926-8865
757-926-8311 FAX
mredifer@nngov.com

Reed, Gregory (1)
Plumbing Inspector
Loudoun County
PO Box 7000 MSC 60B
Leesburg, VA 20177-7000
571-258-3144
703-737-8546 FAX

Revels, Gregory (6)
Building Official
Henrico County
PO Box 27032
Richmond, VA 23273
804-501-4374
804-501-4984 FAX
rev04@co.henrico.va.us

Rexrode, Charles (2)
Building Codes Inspector
City of Harrisonburg
409 South Main Street
Harrisonburg, VA 22802
540-432-7700
540-432-7777 FAX
duker@ci.harrisonburgva.gov

Rigney, Jerry (3)
Director of Inspections
City of Danville
PO Box 3300
Danville, VA 24540
804-799-5263
804-797-8919 FAX
rignejd@ci.danville.va.us

Rimel, III, Paul (2)
Code Inspector II
City of Staunton
116 West Beverly Street
Staunton, VA 24401
540-332-3862
540-332-3807 FAX
rimelpm@ci.staunton.va.us

Rinker, Jr., Larry G. (1)
Mechanical Inspector
Loudoun County
PO Box 7000 MSC 60B
Leesburg, VA 20177-7000
703-771-5503
703-737-8546 FAX

		BECK COHEN
		
Plumbing / Air Conditioning / Heating / Electrical		
(434) 296-0129 Fax (434) 295-3439		
215 Avon Street, Charlottesville, VA 22902		

Roberts, Michale (4)
Building Inspector
Grayson County
PO Box 217
Independence, VA 24348
276-773-2322
276-773-3673 FAX

Robinson, JR., William T. (8)
Cross Connection Specialist
City of Norfolk
400 Granby Street
Norfolk, VA 23510
757-664-6819
757-664-6841 FAX
William.robinson@norfolk.gov

Rogers, Emory (6)
Director, DHCD
501 N. Second Street
Richmond, VA 23219
804-371-7151
804-371-7092 FAX

Roop, Chad (1)
Combination Inspector
Prince William County
1 County Complex Court
Prince William, VA 22192
703-792-7162
croop@pwcgov.org

Ross, John
Technical Assistant
Giles County
315 N. Main Street
Pearisburg, VA 24134
540-921-2527
540-921-1846 FAX
jross@gilescounty.org

Rubino, Donna (1)
Plan Reviewer
Prince William County
5 County Complex Court
Prince William, VA 22192
703-792-4459
703-792-7054 FAX
drubino@pwcgov.org

S

Sanchez, Al (1)
Plan Reviewer
Fairfax County
12055 Government Center Pkwy
Fairfax, VA 22035
703-324-1681
703-324-1614 FAX
al.sanchez@fairfaxcounty.gov

Sanderson, John (6)
Plumbing/Mechanical Inspector
Chesterfield County
PO Box 40
Chesterfield, VA 23832
804-317-6418
804-778-7512 FAX
sandersonj@chesterfield.gov

Sargent, William D. (1)
Chief Plumbing Inspector
Loudoun County
PO Box 7000 MSC 60B
Leesburg, VA 20177-7000
703-771-5685
703-737-8546 FAX
m-40419@aol.com

Schnetzler, Erich (3)
Code Official
Rockbridge County
150 South Main Street
Lexington, VA 24450
540-463-9361
540-463-5981 FAX
erich_schnetzler@co.rockbridge.va.us

Schwind, William M. (5)
Building Official
Orange County
PO Box 111
Orange, VA 22942
540-672-4574
540-672-0164 FAX
ocinspector@orangecova.com

Scofield, Matt (8)
Mechanical Inspector
City of Virginia Beach
2405 Courthouse Drive
Virginia Beach, VA 23456
757-427-8065
757-427-5777 FAX
gscofield@vbgov.com

Seay, Jr., John B. (5)
Commercial Plumbing Inspector
Albemarle County
401 McIntire Rd, #211
Charlottesville, VA 22902
434-296-5832 Ext 3237
434-972-4126 FAX
jseay@albemarle.org

Severson, James A. (6)
Plumbing/Mechanical Inspector
City of Petersburg
106 West Tabb Street
Petersburg, VA 23803
804-733-2409
804-863-2780 FAX

Shapiro, Steven (8)
Chief Building Official
City of Hampton
22 Lincoln Street
Hampton, VA 23669
757-727-6246
757-727-6557 FAX
sschapiro@hampton.gov

Sheppard, Steven (8)
Senior Code Specialist
City of Norfolk
400 Granby Street
Norfolk, VA 23503
757-664-6548
757-664-6897 FAX
steve.sheppard@norfolk.gov

Showman, Geary (2)
Building Code Official
Shenandoah County
600 N. Main Street, Suite 107
Woodstock, VA 22664
540-459-6185
540-459-6193 FAX
gshowman@shenandoahcountyva.us

Silveus, Steven (1)
Plumbing Inspector
Loudoun County
PO Box 7000 MSC 60B
Leesburg, VA 20177-7000
703-771-5497
703-737-8546 FAX

Smallwood, Sr., Charles (1)
Mechanical Inspector
Loudoun County
P.O. Box 7000 MSC 60B
Leesburg, VA 20177-7000
703-771-5066
703-737-8546 FAX

Smith, Charles (1)
Plumbing Inspector
Loudoun County
PO Box 7000 MSC 60B
Leesburg, VA 20177-7000
703-737-8986
703-737-8546 FAX

Smith, Douglas (8)
Code Official
Town of Cape Charles
2 Plum Street
Cape Charles, VA 23310
757-331-3259 Ext 16
757-331-4820 FAX
codeofficial@capecharles.org

Smith, Ken (1)
Master Combination Inspector
Fairfax County
12055 Government Center Pkwy
Fairfax, VA 22035
703-324-1703
703-324-1846 FAX
kenneth.smith@fairfaxcounty.gov

Smith, Sharon (6)
Certification Manager, DHCD
501 N. Second Street
Richmond, VA 23219
804-371-7185
804-371-7092 FAX
sharon.finan@dhcd.virginia.gov

— Active Roster Continued —

Smith, Wes (5)
Building Official
Madison County
PO Box 1206
Madison, VA 22727
540-948-6102
540-948-3939 FAX
wsmith@madisonco.virginia.gov

Snider, Jason D.
Building Inspector
County of Rockbridge
150 S. Main Street
Lexington, VA 24450
540-463-9361
540-463-5981 FAX
jason_snider@co.rockbridge.va.us

Snyder, Sr., Kenneth R. (2)
Life Member
41 Fairmont Drive
Staunton, VA 24401
540-885-2971
kenandbarbva@aol.com

Snyder, Paul (5)
Building Official
Louisa County
PO Box 160
Louisa, VA 23093
540-967-3430
540-967-3458 FAX
psnyder@louisa.org

Spence, Brown (1)
Chief Mechanical Inspector
Loudoun County
PO Box 7000 MSC 60B
Leesburg, VA 20177-7000
703-771-5059
703-737-8546 FAX
bspence@loudoun.gov

Stanley, Dennis (3)
Assistant Building Official
City of Salem
PO Box 869
Salem, VA 24153
540-375-3036
540-375-3003 FAX
dstanley@ci.salem.va.us

Stephen, Darryl (8)
Senior Mechanical Inspector
City of Norfolk
400 Granby Street
City of Norfolk, VA 23510
757-664-6562
757-664-6841 FAX
Darryl.stephen@norfolk.gov

Stevens, Eric C. (1)
Plumbing Inspector
Prince William County
1 County Complex Court
Prince William, VA 22192
703-792-6969
703-580-1578 FAX
estevens@pwcgov.org

Stevens, Michael (1)
Plumbing Inspector
Prince William County
1 County Complex Court
Prince William, VA 22192
703-792-6969
mstevens@pwc.org

Stewart, Danny L. (8)
Plumbing Inspector
City of Virginia Beach
2405 Courthouse Drive
Virginia Beach, VA 23456
757-385-8066
757-385-5777 FAX

Stickel, Donald (3)
Building Official
Pittsylvania County
53 North Main Street
Chatham, VA 24531
434-432-7755
434-432-7919 FAX
d.stickel@pittgov.org

Stover, Douglas L. (2)
Life Member
Rockingham County (Ret.)
PO Box 1252
Harrisonburg, VA 22801
540-564-3030
540-434-7163 FAX

Stump, Gary (1)
Building Inspector II
Town of Herndon
PO Box 427
Herndon, VA 20172
703-435-6850
703-318-8492 FAX
gary.stump@herndon-va.gov

Strausbaugh, Shan (1)
Plans Examiner
Arlington County
2100 Clarendon Blvd, Suite 804
Arlington, VA 22201
703-228-3874
703-228-3777 FAX
sstrausbaugh@arlingtonva.us

Street, John (8)
Combination Inspector
City of Williamsburg
401 Lafayette Street
Williamsburg, VA 23105
757-220-6136
757-259-3798 FAX
jstreet@williamsburg.gov

Stubanus, Gregory (2)
Code Enforcement
City of Waynesboro
250 S. Wayne Avenue, Rm #208
Waynesboro, VA 22980
540-942-6628
540-942-6770 FAX
stubanusgc@ci.waynesboro.va.us

Sulzer, Caleb (5)
Building Inspector
Louisa County
PO Box 160
Louisa, VA 23093
540-967-3430
540-967-3486 FAX
csulzer@louisa.org

Sutton, Chuck (8)
Inspector Coordinator
City of Virginia Beach
2405 Courthouse Drive
Virginia Beach, VA 23456
757-385-4211
757-385-5777 FAX
cwsutton@vbgov.com

Swortzel, Michael (2)
Inspector
Augusta County
PO Box 590
Verona, VA 24482
540-245-5717
540-245-5721 FAX
bi@co.augusta.va.us

T

Thrash, Mark Gregory (6)
Residential Combination Inspector
Chesterfield County
PO Box 40
Chesterfield, VA 23832
804-814-6984
thrash@chesterfield.gov

Thuot, Michael
Retired
3197 Adam Keeling Road
Virginia Beach, VA 23452
540-349-8748
mthout@aol.com

Tillman, L. Del (8)
Sr. Plumbing/Mechanical Inspector
City of Hampton
22 Lincoln Street
Hampton, VA 23669
757-727-6790
757-727-6557 FAX

Tobin, Sr., Cordell S. (1)
Construction Plans Examiner
Arlington County
2100 Clarendon Blvd, Suite 800
Arlington, VA 22201
703-228-3874
703-228-7046 FAX
ctobin@co.arlington.va.us

Tomberlin, Guy (1)
Life Member
Chief Plumbing Inspector
Fairfax County
12055 Government Center Pkwy
Fairfax, VA 22035
703-324-1611
703-324-1846 FAX
guy.tomberlin@fairfaxcounty.gov



FITZGERALD**ART**&DESIGN^{LLC}

703-527-1238

info@fitzart-d.com



Tribute to William "Til" Hazel, 20" x 16", mixed media. 2007

www.fitzart-d.com

— Active Roster Continued —

Trenary, John S. (2)
Building Official
Frederick County
107 North Kent Street
Winchester, VA 22601
540-665-5656
540-678-0682 FAX
jtrenary@co.frederick.va.us

Toney, Chris (5)
Combination Inspector
Spotsylvania County
10304 Spotsylvania Avenue
Fredericksburg, VA 22408
540-507-7238
mtoney@spotsylvania.va.us

Truslow, Paul (5)
Codes Inspector
Nelson County
PO Box 336
Lovingson, VA 22949
434-263-7080
434-263-7086 FAX
ptruslow@nelsoncounty.org

V

Vannoy, Johnny (1)
Combination Inspector
Fairfax County
12055 Government Center Pkwy,
Suite 634
Fairfax, VA 22035
703-475-0615
703-324-3901 FAX
johnny.vannoy@fairfaxcounty.gov

W

Walker, Thomas (6)
Plumbing Inspector
City of Richmond
900 East Broad Street, #110
Richmond, VA 23219-6505
804-780-6962
804-785-6948 FAX

Ward, Allen (8)
Building Official
Mathews County
PO Box 839
Mathews, VA 23109
804-725-7171
804-725-0560 FAX

Ward, Danny Roy (5)
Building Inspector
Madison County
PO Box 1206
Madison, VA 22727
540-948-6102
540-948-3939 FAX
dward@madisonco.virginia.gov

Watts, Marion (4)
Building Official
Town of Abingdon
PO Box 789
Abingdon, VA 24212
276-628-6611
276-628-9986 FAX
mdwatts@abingdon.com

Werres, Joseph (5)
Inspector/Project Manager
Albemarle County
401 McIntire Rd, #211
Charlottesville, VA 22902
434-296-5816
434-293-0294 FAX

Westfall, Bobby (1)
Plumbing Inspector
Loudoun County
PO Box 7000, MSC 60B
Leesburg, VA 20177-7000
703-737-8646
703-737-8546 FAX

White, Barry (6)
Combination Inspector
Chesterfield County
PO Box 40
Chesterfield, VA 23832
804-748-1210
804-778-7512 FAX
whiteb@chesterfield.gov

Williams, Michael A. (2)
Plans Examiner
City of Harrisonburg
409 South Main Street
Harrisonburg, VA 22802
540-432-7700
540-432-7777 FAX
mikew@harrisonburgva.gov

Wills, Andrew (5)
Building Inspector
Fluvanna County
PO Box 540
Palmyra, VA 22963
434-591-1935
434-591-1911 FAX
awills@co.fluvanna.va.us

Wilson, Brian (8)
Cross Connection Specialist
City of Norfolk
400 Granby Street
Norfolk, VA 23510
757-664-6840
757-664-6841 FAX
brian.wilson@norfolk.gov

Wilson, Kenny (3)
Combination Inspector
Rockbridge County
150 South Main Street
Lexington, VA 24450
540-463-9361
540-463-5981 FAX
kenny_wilson@rockbridge.va.us

Windon, James
Chief Plumbing Inspector
Harford County
220 South Main Street
Belair, MD 21014
410-638-3215
410-879-8203 FAX
plumbing@co.ha.md.us

Witt, Richard (6)
Assistant Building Official
Chesterfield County
PO Box 40
Chesterfield, VA 23832
804-751-4161
804-757-4713 FAX
witt@chesterfield.gov

Wood, Murphy (3)
Building Inspector
City of Salem
PO Box 869
Salem, VA 24153
540-375-3036
mwood@salemva.gov

Woolard, Wayne (8)
Plumbing/Mechanical Inspector
City of Hampton
22 Lincoln Street
Hampton, VA 23669
757-727-6286
757-727-6557 FAX
wwoolard@hampton.gov

Woolford, Eric (5)
Building Inspector
Greene County
PO Box 358
Stanardsville, VA 22973
434-985-5204
434-985-1459 FAX
ewoolford@gcva.us

Y

Yoder, Leon (8)
Plans Reviewer
City of Norfolk
400 Granby Street
Norfolk, VA 23510
757-664-6815
757-664-6841 FAX
Leon.Yoder@norfolk.gov

Yun, Sunguk (1)
Critical Structures
Fairfax County
12055 Government Center Pkwy
Fairfax, VA 22035
703-324-1051
sunguk.yun@fairfaxcounty.gov

Z

Ziegler, Joseph (5)
Residential Combination/Commercial
Inspector
Spotsylvania County
10304 Spotsylvania Avenue, Ste. 400
Fredericksburg, VA 22408
540-507-7249
540-710-7119 FAX
jziegler@spotsylvania.va.us

Updated as of March 2008

— 2007-8 Associate Member Roster —

Bold Type indicates "Life Member" status

Allen, Marlund R.
COO
LA Lacy, Inc.
900 Harns Street
Charlottesville, VA 22903
434-296-7542
434-293-9073 FAX
marlund@lalacy.com

Anderson, Kenneth
Virginia Beach City Public Schools
29525 N. Landing Rd
Virginia Beach, VA 23456
757-427-5300
757-427-5558 FAX
keanders@vbcps.k12.va.us

Archer, Bradford
Construction Management &
Administration
1734 Seibe Drive
Roanoke, VA 24012
540-344-7939
540-344-3657 FAX

Bates, Jr., William T.
Foley Plumbing
6418 E Old Meetze Rd
Warrenton, VA 20187
540-428-3290
540-428-3295 FAX
foleyking@verizon.net

Becker, David
Potomac Energy Group
20 S. Quaker Lane
Alexandria VA 22314
703-683-5000
daveb@pegroup.net

Bess, Robert M.
Plumbers/Steamfitters Local #1
701 Stockton Street
Richmond, VA 23224
804-231-4232
804-231-4235 FAX

Borden, Fred W.
Fred W. Borden, Inc.
4174-A Old Stockyard Rd.
Marshall, VA 20115
703-378-8484
703-378-6359 FAX
fwbordenplumbing@aol.com

Buckner, William W.
Greenbeck Enterprises
608 Van Fossen Street
Winchester, VA 22601
540-662-7638
540-662-1773 FAX
bbuckner@visuallink.com

Brown, Jeremy
Codes & Regulatory Manager
789 N. Dixboro Rd.
Ann Arbor, MI 48105
734-769-5796
737-827-7129 FAX
brown@nsg.org

Burkert, Chris
Capital Inspections
P.O. Box 1321
Centreville, VA 20120
703-222-8826
cab2326@aol.com

Cathell, Edward K.
Walter E. Cathell Assoc. Inc
6609 York Road
Baltimore, MD 21212
410-323-9881
410-433-1548 FAX
ekcathell@yahoo.com

Cole, Stanton R.
Purchasing/Fleet Manager
Southern-Air, Inc.
2655 Lakeside Drive
Lynchburg, VA 24502
434-385-1261
434-385-7515 FAX
Ronnie.Cole@southern-air.com

Colton, Richard B.
Master, Inc.
7891 Beechcraft Ave
Gaithersburg, MD 20879
301-252-3308
301-258-7368 FAX
bruce.colton@mastersco.com

Conover, David R.
Senior Advisor, ICC
500 New Jersey Ave., NW,
Suite 600
Washington, DC 20001
202-370-1800 Ext 6244
DConover@iccsafe.org

Crigler, Laurie & Daniel
L & D Associates
P.O. Box 418
Aroda, VA 22709
540-948-6230
540-948-5617 FAX
lcrigler@ns.gemlink.com

Edwards, Tim
Regional Engineer
Advanced Drainage Systems
13320 Meredith Pointe Way
Chesterfield, VA 23832
804-922-2289
804-739-2866 FAX
tim.edwards@ads-pipe.com

Finney, Jeffrey Dean
Nationwide Custom Homes
P.O. Box 5511
Martinsville, VA 24115
540-632-7100
540-632-1181 FAX
jfinney@nationwidecustomhomes.com

Given, Alan
Parish Services
7865 Coppermine Drive
Manassas, VA 20109
703-330-5748
703-330-0599 FAX
alange@parishservices.com

Hardee, Sr., Cecil F.
Life Member
203 Bayswater Ct.
New Bern, NC 28562

Hibbs, Evan C.
Evan C. Hibb, Inc.
957 Chautauqua Ave
Portsmouth, VA 23707
757-393-7401
757-393-7403 FAX
even@evanhibbs.com

Jinks, Scott
J & S Plumbing
P.O. Box 1628
Manassas, VA 20108
703-721-5095
royalflush0108@yahoo.com

Johnston, David
5111 Lavery Court
Fairfax, VA 22032
703-503-0644

Kalish, Susan
National Fireplace Institute
1901 N. Moore St. Ste 600
Arlington, VA 22209
703-524-8030
703-522-0548 FAX
kalish@hpba.org

Kellogg, Stephen
Water Solution Account Executive
4987 Cleveland Street, #106
Virginia Beach, VA 23462
757-490-9110
757-490-9001 FAX
dryit@waterdamagessolutions.biz

Kelley, George "Duke"
GSSN
102 Lipizzaner Court
Stephens City, VA 22655
540-868-1146
540-868-1146 FAX
gssn-corp@hotmail.com

Kidd, Jerry
Beck Cohen Inc
215 Avon Street
Charlottesville, VA 22902
434-296-0129
434-295-3439 FAX
beckcohen@yahoo.com

(Continued on next page)

— Associate Roster Continued —

Kreutzer, Tom
Woodbridge Plumbing, Inc.
2705 Code Way
Woodbridge, VA 22192
703-494-9666
703-494-0739 FAX

Leonard, Gary E.
Leonard-Splaine Company, Inc.
13300 Occoquan Road
Woodbridge, VA 22191
703-494-2855
703-494-8305 FAX
Leonard.gary@hotmail.com

Maher, J. Richard
Life Member
307 Cadmus Circle
Gordonsville, VA 22942
703-832-5313

Maupin, David
W.E. Brown, Inc.
915 Monticello Rd
Charlottesville, VA 22902
434-295-1177
434-979-1394 FAX
dave@webrown.com

McMahon, James
Cast Iron Soil Pipe Inst.
925 Seaman Ave.
Beachwood, NJ 722
703-644-5146
castironjim@mindspring.net

Mitchell, Sr., Radford H.
Virginia Beach City Public Schools
4400 Virginia Beach Blvd.
Virginia Beach, VA 23462
757-473-5000
757-473-5004 FAX
ramitchell@vbcp.s.k12.va.us

Muncy, James B.
Life Member
President, MAMS, Inc.
7711 Mendota Drive
Richmond, VA 23229
804-288-5664
804-282-1620 FAX

Nuckols, J.C.
Nangle, Heather
PMPV Executive Director
P.O. Box 307
Fairfax, VA 22039
800-947-7450
800-947-7415 FAX
hnangle@mac.com

Olsen, Ricky
Fort Hunt Plumbing
1906 Mallinson Way
Alexandria, VA 22308
703-799-9356
703-7991754 FAX
plumb369@aol.com

Outland, John Jay
Prince William County School Board
P.O. Box 389
Manassas, VA 20108
703-791-7221
703-791-7481 FAX
outlandj@pwcs.edu

Peed, Gary
President, Peed Plumbing Inc.
11721 Pump Station Way
Manassas, VA 20109
571-229-1234
garypeed@peedplbg.com

Pittenger, Robert E.
Beach Services
9553 First View St.
Norfolk, VA 23503
757-480-7260
bchplmbserve@att.net

Qualified Gas Contractors Assoc.
of South Hampton Roads
5100 E. Virginia Beach Blvd
Norfolk, VA 23503
757-466-5579
757-466-5437 FAX

Rao, Jr., Charles T.
Richmond Marketing, Inc.
2535 Mechanicsville Turnpike
Richmond, VA 23223
804-643-7355
804-643-7380 FAX
rmi@ricmrk.com

Sargeant, Jonathan D.
National Accounts Manager
Jay R. Smith Manufacturing Co.
4024 St. Elmo Avenue
Chattanooga, TN 37409
423-883-3137
423-207-4840 FAX
Jon.Sargeant@jrsmith.com

Simounet, Craig
President, Capital Mechanical, LLC
45037 Moran Drive
Dulles, VA 20166
703-443-9323
703-433-9579 FAX
csimounet@aol.com

Smith, Sr., Oscar
Oscar W. Smith Mechanical
2612 Jackson Drive
Salem, VA 24153
540-389-8041
540-387-4590 FAX

Sovern, Robert J.
Atlantic Constructors, Inc.
1401 Battery Brooke Parkway
Richmond, VA 23237
804-222-3400
804-233-5970 FAX
robertsovern@atlanticconstructors.com

Steinle, Jim
Life Member
Owner
Atomic Plumbing
1377 London Bridge Road
Virginia Beach, VA 23453
757-464-2934
757-363-8403 FAX
Jim@atomicplumbing.com

Stilwell, P. Wayne
President
PW. Stilwell Plumbing/Htg
13482 Still Well Lane
Brandy Station, VA 22714
540-825-0025
540-825-0650 FAX

Strickler, Jasper
Post Office Box 728
Stuarts Draft, VA 24477
540-942-5207
strickler@yahoo.com

Tamres, Joseph
Hartford Steam Boiler, Insp
2563 James Madison Cr
Herndon, VA 20171
703-713-3467
703-713-3467 FAX
joseph_tamres@hsb.com

Tryall, Allen
Beck Cohen, Inc
215 Avon Street
Charlottesville, VA 22902
434-296-0129
434-295-3439 FAX

West, Charles H.
Wells 7 West, Inc
P.O. Box 129
Murphy, NC 28906
828-837-2437
828-837-3152 FAX

Wiggins, John R. (P.E.)
Underwriters Laboratory
12 Laboratory Dr
RTP, NC 27709
919-549-1502
919-547-6454 FAX
johnr.wiggins@us.ul.com

Wood, Tommy
CEO
Woodbridge Plumbing, Inc
2705 Code Way
Woodbridge, VA 22192
703-494-9666
703-494-0739 FAX
twood@woodbridgeplumbing.com

— Membership Application Form —

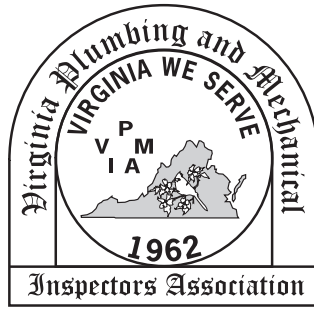

I the undersigned, hereby make application for membership, and if accepted, I agree to abide by the Constitution and By-laws of the Association, perform all requested duties and support the Association to the best of my abilities. I understand the membership fee shall cover the period from January 1st to December 31st, any payment received during the year shall cover only the remainder of the year.

Name _____

Title _____

Jurisdiction or Firm _____

Address _____

City _____ State _____ Zip _____

Telephone No. _____ Fax _____

E-Mail Address _____

Signature _____ Date _____

ACTIVE MEMBERSHIP FEE: \$30.00
Active members must be employed by a government agency.

{ } Please check this block if you are a designated ICC voter, representing your municipality or jurisdiction.

ASSOCIATE MEMBERSHIP FEE: \$35.00
Associate members shall consist of persons interested in assisting the Association in promoting the safety, health and welfare of the public. Associate members must be approved, for membership in the Association, by the Board of Directors.

Make checks payable to: Virginia Plumbing and Mechanical Inspectors Association (VPMIA)

Please Mail To:

Geary Showman, BCO
VPMIA Executive Secretary
600 N. Main Street
Woodstock, VA 22664-3551

VPMIA USE ONLY

Date: _____

Check Number: _____

Amount(\$): _____

More than 40 years dedication to the code enforcement community.

2005 ICC Merit Award Recipient for the Chapter of the Year Contest.

Connect with VPMIA today.



VPMIA is an

association of code professionals dedicated to promotion

VPMIA is an association of code professionals dedicated to promotion of uniform enforcement and development of the codes throughout the Commonwealth to assure the health, safety, and welfare of its citizens and any one who may live, work, or visit the state of Virginia.

The pursuit of this endeavor is achieved through close, open, and equal working relationships with design professionals, builders, contractors, material manufacturer's and others involved in the construction industry. VPMIA supports the ICC, its goals and mission.

Virginia Plumbing and Mechanical Inspectors Association
www.vpmia.org

Thinking green. It's a Ductmate thing.



At Ductmate, we've been a product innovator and engineering solutions provider for more than 30 years. Through those decades, we've garnered over two dozen worldwide and U.S. patents, and a litany of HVAC product awards. But this one is special. The Green Building Alliance® Product Innovation Grant is a recognition of our ability to invent, grow, and develop product innovations that promise to make a significant impact on the green building industry.

This grant is awarded to projects that seek to develop and introduce new and enhanced green building products. GreenSeam™ is a unique self-sealing snap-lock pipe, designed to provide increased efficiency for residential and commercial HVAC applications. Engineering simplicity is the key to GreenSeam's effectiveness. By integrating a gasket into the entire length of the longitudinal snap-lock seam, GreenSeam reduces leakage by 95% along the longitudinal seam without depending on external tapes or sealants. GreenSeam has quickly become a cost-effective key component of today's sustainable HVAC systems.

So, while we are honored to have received this recognition, we see it as simply the result of doing what we do. Thinking Green. It's a Ductmate thing. To learn more, call us at 1-800-245-3188, or visit our Online Information Center at www.ductmate.com.



One Source. Infinite Solutions.

800-245-3188 • www.ductmate.com



GreenSeam's integrated gasket reduces leakage by 95% along the longitudinal seam without the need for sealants.





7405 ALBAN STATION COURT
SUITE A-107
SPRINGFIELD, VA 22150
(703) 455-5520 (O)
(703) 455-5530 (F)
got2fishordie@yahoo.com

ARCHITECTS  ENGINEERS  CONTRACTORS



RESIDENTIAL  COMMERCIAL

Your Family Deserves The Best.



For the protection and safety of your family and your home, it pays to hire a professional plumbing-heating-cooling contractor.

Over 4,100 companies nationwide are qualified members of the Plumbing-Heating-Cooling Contractors Association (PHCC). Each member company stands for the health, safety and comfort of homeowners and protection of our environment. A professional p-h-c contractor will safeguard your home from carbon monoxide poisoning, water damage, sewer gas releases, scalding, mold, waste water leaks,

and potential injuries related to improper installation and maintenance. Whether you're modernizing an entire system or simply need a repair, make sure you choose a trained, full-time professional—not someone who does this type of work "on the side." Do you really want to chance these important and potentially dangerous tasks to a non-professional?



WWW.PMPV.ORG
800-947-7450

Be Safe. Be Smart. Hire a PHCC Professional.

This public service message
provided by the PHCC
Partners for Professionalism.



For information on how to hire a professional contractor, visit our Web site at www.phccweb.org and click on Find a Contractor. Or call our toll free number 800-533-7694 and we'll put you in touch with a PHCC member in your area.

ACCA HVAC DESIGN MANUALS

AS REFERENCED BY THE **IRC, IMC, AND IECC**

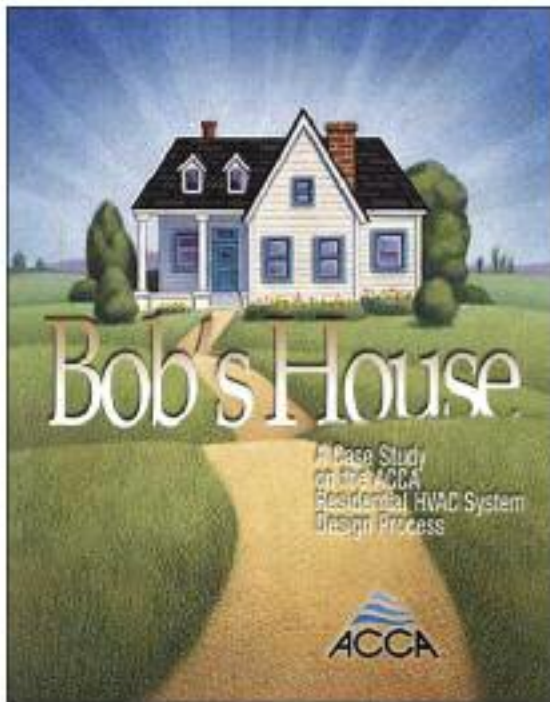

Bob's House

An illustrated guide to the residential HVAC design process
(ACCA Manual J & D)

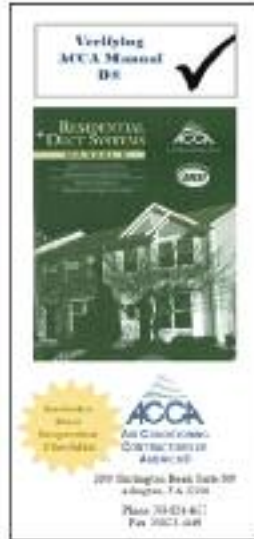
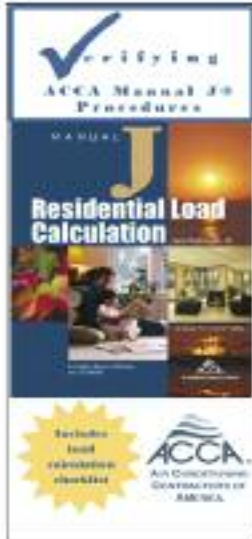
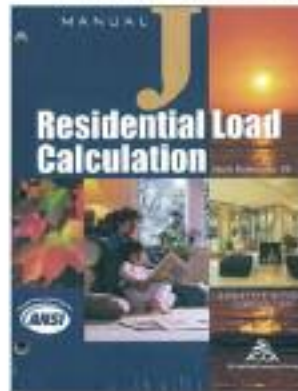

Free guides for verifying contractor compliance at:
acca.org/tech/codes



FOR SUPPORT AND OTHER MEMBERSHIP BENEFITS VISIT
WWW.ACCA.ORG